



MANUAL OF PROCEDURES

FOR

E A R T H W O R K
C O N S T R U C T I O N

VOLUME I

JANUARY 1998

An Equal Opportunity Employer



VOLUME I

FOREWORD

The purpose of this manual is to provide construction personnel with information necessary to control the work so that the earthwork items of highway construction will be performed in accordance with requirements of the contract. This manual is available to construction personnel as a source of ready reference, and it is the duty of field personnel to become familiar with the contents.

Included is condensed background information on soil properties, soil identification and classification, and laboratory test for soil. It is intended that this background information will help construction personnel understand soil terms used in the specifications and in these detailed instructions.

The entire Earthwork manual is not part of the contract with the Contractor. The information contained in the manual does not replace, supersede or modify any specification, plan or proposal provision of the contract. But the field testing portion of the manual is part of the contract in accordance with 203.02.

In the interest of brevity, some detailed information which is available elsewhere is not included in this manual. This manual should not be considered a complete textbook on soils, engineering or earthwork.

This manual is divided into two volumes. Both are to be used for Earthwork Construction.



INTRODUCTION

Earthwork consists of roadway excavations (cuts) and roadway embankments (fills) for highways and associated items of work. Earthwork includes all types of materials excavated and placed in embankment, including soil, granular material, rock, shale, and random material. Associated items of work considered to be in the broad range of earthwork include clearing and grubbing, removal of trees and stumps, scalping, removal of structures and obstructions, channel excavation, preparation of foundations for embankment, disposal of excavated material, borrow, preparation of subgrade, proof rolling, subbase, and temporary water pollution, soil erosion and siltation control. If pavement is to remain smooth and stable during years of service under traffic, the earthwork on which it is built must be stable and must furnish uniform support. Where roughness, settlements and other distress develop in pavement during service under traffic, the cause often is a deficiency in the stability of earthwork which supports the pavement.

Uniformity of earthwork is necessary and important to obtain high stability and long term performance at all locations throughout the length and width of the

project. Consider, for example, a highway project where 95 percent of the earthwork was performed in accordance with the specifications. But 5 percent was nonspecification and low stability material which occurred in many small areas distributed throughout the project. Pavement roughness and distress developed in these areas during service under traffic loading. Such a project probably would be evaluated by the traveling public as a "rough job" or a "poorly constructed" project. No notice or credit would be given to the 95 percent of the work which was constructed properly. The entire project might be discredited and considered poor because of a relative small proportion of poor earthwork construction.

The foregoing assumed example is intended to illustrate the need for consistent compliance with earthwork specifications in all areas, both large and small, throughout the length of the project, and throughout the time from the beginning to the end of earthwork construction.



METRICATION

This version of the manual has been converted to metric units. All tables, forms, graphs, curves and tests are in dual units. The metric units are first and the English units are in parenthesis, i.e., metric (English). All forms ending with a M are metric. (For example, C-88M is the metric compaction form and C-88 is the English form.) Weight measurements can be measured to the nearest 0.1 of a kilogram. Normally rounded to nearest whole kilogram on the compaction forms. For higher accuracy record to nearest 0.1 of a kilogram. The following are some of the conversions used in this manual.

$\text{in}^2 \times 645.2 = \text{mm}^2$	Area	rounded
$\text{lbs} \times 0.4536 = \text{kg}$	Weight	rounded
$\text{lbs} \times 4.44822 = \text{N}$	Force	rounded
$\text{lbs} \times 453.6 = \text{grams}$	Weight	
$\text{ft} \times 0.3048 = \text{m}$	Length	
$\text{ft}^2 \times (0.3048)^2 = \text{m}^2$	Area	

$$\text{yd}^3 \times 27 \text{ ft}^3 / \text{yd}^3 \times \frac{(0.3048)^3(\text{m}^3)}{\text{ft}^3} = \text{m}^3 \quad \text{volume}$$

$$\text{yd}^3 \times 0.76455 = \text{m}^3 \quad \text{volume}$$

$$\text{lb} / \text{ft}^3 \times \frac{0.4536 \text{ kg}}{\text{lb}} \times \frac{\text{ft}^3}{(0.3048)^3(\text{m}^3)} = \text{kg} / \text{m}^3$$

$$\text{lb} / \text{ft}^3 \times 16.01873 = \text{kg} / \text{m}^3 \quad \text{Density}$$

$$\text{psi} \times 6.89476 = \text{kPa pressure}$$

$$\text{psi} \times 0.00689476 = \text{MPa pressure}$$



VOLUME I

TABLE OF CONTENTS

Section	Page	Old Section*
Forward	i	1
Introduction	ii	2
Metrication	iii	
Chapter 1.0 Index	1-1	new
1.0 General Soils Information	1-3	3
1.1 Soil and Soil Properties	1-3	3
1.2 Classification of Soils and Soil-Aggregate Mixtures	1-10	4
1.3 Crude Soil Identification Techniques Used in the Field	1-15	new
1.4 Engineering Properties of Soils	1-16	new
Chapter 2.0 Index	2-1	new
2.0 General Earthwork Construction	2-3	
2.1 Removal of Trees and Stumps	2-3	6
2.2 Temporary Water Pollution, Soil Erosion and Siltation Control	2-5	9
2.3 Borrow and Waste Areas	2-10	15
2.4 Elasticity and Deformation of Soils	2-13	11.3
2.5 Foundation for Embankments	2-15	7
2.6 Proof Rolling Subgrade	2-17	13
2.7 Drainage	2-21	10

Section	Page	Old Section*
Chapter 3.0 Index	3-1	new
3.0 Moisture Control and Testing	3-2	11, 20
3.1 Moisture Control of Soil Embankments During Construction	3-2	11.2
3.2 Tests for Moisture	3-2	20
3.3 Nuclear Gauge Test for Moisture	3-3	20.8
3.4 Oven-Drying Method	3-5	20.2
3.5 Open-Pan Drying Method	3-6	20.4
3.6 Alcohol-Burning Drying Method	3-6	20.5
3.7 Gasoline-Burning Drying Method	3-7	20.6
3.8 Moisture-Density Curve Method	3-7	20.3
Chapter 4.0 Index	4-1	new
4.0 Compaction of Soils	4-2	
4.1 Compaction	4-2	14
4.2 Moisture-Density Relationship	4-3	3.13
4.3 Variations of the Moisture-Density Relationship	4-5	new
4.4 Test for Moisture-Density Relations and Penetration Resistance of Soils	4-7	21
4.5 Using the Ohio Typical Curves	4-9	21.4
Chapter 5.0 Index	5-1	new
5.0 Compaction Testing of Soils	5-2	23
5.1 Equipment	5-2	23.2
5.2 Preparation of Test Site	5-2	23.3
Chapter 6.0 Index	6-1	new
6.0 Compaction Testing of Soil Using a Nuclear Gauge	6-2	23.4.3.1
6.1 Density Test	6-3	23.4.3.1
6.2 Selecting a Typical Curve Using the Nuclear Gauge Results	6-5	23.6.3

VOLUME II

TABLE OF CONTENTS

Section	Page	Old Section*
Chapter 7.0 Index	7-1	new
7.0 Compaction Testing of Soil Using the Sand Cone Method	7-2	23.4.1
7.1 Procedure Using the Sand-Cone Method	7-2	23.4.1
7.2 One Point Proctor Test	7-4	23.5
7.3 Penetration Resistance Determination	7-5	23.5.1
7.4 Selection of Moisture-Density Curve	7-6	23.6
7.5 Calculation of Compaction	7-10	23.7
7.6 Check for Specification Compaction Requirements	7-11	23.11
7.7 Check for Specification Moisture Requirements	7-12	23.12
7.8 Check Using Zero Air Voids Formula	7-13	23.9
7.9 Check Using Zero Air Voids Curve	7-14	23.10
7.10 Precautions to Prevent Errors	7-15	23.8
 Chapter 8.0 Index	 8-1	 new
8.0 Compaction Testing of Soil Using the Cylinder Density Test	8-2	23.4.4
8.1 Description	8-2	23.4.4.1
8.2 Condition of Use	8-2	23.4.4.2
8.3 Equipment	8-2	23.4.4.3
8.4 Determining Wet Density	8-3	23.4.4.4
8.5 Determining Percent Compaction Procedure	8-5	23.4.4.5
8.6 Procedure for Multiple Density Tests	8-5	23.4.4.7

Section	Page	Old Section*
Chapter 9.0 Index	9-1	new
9.0 Compaction Testing for Granular Materials	9-2	24
9.1 General Explanation	9-2	24.1
9.2 Equipment for Compaction Testing	9-3	24.2
9.3 Granular Moisture-Density Curve Determination	9-4	22
9.4 Density Determination of Granular Material Using a Troxler Nuclear Gauge on Form C-135 B-M (C-135B)	9-6	new
9.5 Density Determination of Granular Material Using the Sand-Cone on Form C-90M (C-90)	9-7	24.3.1
9.6 Compaction Control Using the Test Section Method for Granular Materials, Subbases and Aggregate Bases	9-9	17
 Chapter 10.0 Index	 10-1	 new
10.0 Earthwork Inspections, Tests, Reports, Controls, and Calculations	10-2	5, 8, 18
10.1 Inspection and Tests	10-2	5
10.2 Construction Controls and Final Earthwork Reports	10-3	3
10.3 Earthwork Quantity Calculations	10-6	18
10.4 Check List for Earthwork Calculations	10-8	19
 11.0 Documentation	 11-1	
 12.0 Blank Forms	 12-1	

List of Figures

Figure		Page	Old Section*
1-1	Water Effects on Soils	1-9	new
1-2	Classification of Soils	1-13	4-1
1-3	Graphical Determination of Group Index	1-14	4-2
2-1	Swamp Treatment	2-16	7-1
2-2	Load and Tire Pressures for Proof Rolling	2-20	13-1
3-1M	C-88M Report on Compaction	3-8	new
3-1	C-88 Report on Compaction	3-9	20-1
4-1	Effects of Compaction on Soils	4-10	new
4-2	Temperature Effects on Soil	4-11	new
4-3	Coarse Aggregate Effects on Soils	4-12	new
4-4	Work Sheet for a Moisture-Density Test	4-13	21-1
4-5M	Moisture-Density and Penetration Resistance Curves	4-14	21-2
4-5	Moisture-Density and Penetration Resistance Curves	4-15	21-2
4-6	Loose and Compacted Lifts for the Proctor Test	4-16	new
4-7M	Ohio Typical Density Curve	4-17	new
4-7	Ohio Typical Density Curve	4-18	new
6-1	Nuclear Gauge Direct and Backscatter Position	6-6	new
6-2	Nuclear Gauge at the Standard Count Position	6-7	new
6-3	3440 Keypad Layout	6-8	new
6-4	Scaper Plate Tools and Use	6-9	new
6-5	Positions of the Nuclear Gauge	6-10	new
6-6M	Example of C-135 B-M Nuclear Gauge Compaction Form	6-11	new
6-6	Example of C-135 B Nuclear Gauge Compaction Form	6-12	new
7-1M	C-88M Example of Sand-Cone Test Using Drying Method	7-16	new
7-1	C-88 Example of Sand-Cone Test Using Drying Method	7-17	new
7-2M	C-88M Example of Sand-Cone Test Using Penetration Resistance	7-18	23-1
7-2	C-88 Example of Sand Cone Test Using Penetration Resistance	7-19	23-1
7-3	Circular Slide Rule	7-20	23-10
7-4M	Plotted Ohio Typical Density Curves	7-21	23-9
7-4	Plotted Ohio Typical Density Curves	7-22	23-9
7-5M	C-88M Example of Sand Cone Test with More than 10% passing 19 mm (3/4") Sieve	7-23	new
7-5	C-88 Example of Sand Cone Test with More than 10% passing 19 mm (3/4") Sieve	7-24	new
7-6	Sand Cone Apparatus	7-25	23-2
7-7M	Zero Air Voids Curve	7-26	23-12
7-7	Zero Air Voids Curve	7-27	23-12

List of Figures (continued)

Figure		Page	Old Section*
8-1	Cylinder Density Apparatus	8-6	23-7
8-2M	Example of C-89M Compaction Test Using the Cylinder Density Method	8-7	23-8
8-2	Example of C-89 Compaction Test Using the Cylinder Density Method	8-8	23-8
9-1M	Moisture-Density Curve for Granular Material	9-12	22-2
9-1	Moisture-Density Curve for Granular Material	9-13	22-2
9-2M	Example of C-90M Density Determination Using the Sand Cone Method	9-14	22-1
9-2	Example of C-90 Density Determination Using the Sand Cone Method	9-15	22-1
9-3M	Example of C-135B-M Nuclear Gauge Compaction Form	9-16	new
9-3	Example of C-135B Nuclear Gauge Compaction Form	9-17	new
10-1M	End Area Determination (Method 1)	10-9	18-1
10-1	End Area Determination (Method 1)	10-9	18-1
10-2M	End Area Determination (Method 2)	10-10	18-2
10-2	End Area Determination (Method 2)	10-10	18-2
10-3	Cubic Yards for the Sum of End Areas	10-11	18-3
10-4	Example of Procedures for Determininig Corrected Arc Lengths Between Centroids	10-12	18-4



INDEX

Chapter 1.0 General Soils Information

Section/Figure	Page	Old Section
1.1 Soil and Soil Properties	1-3	3
Soil.....	1-3	3.1
Soil Sizes	1-3	3.2
Texture	1-4	3.3
Soil Components	1-4	3.3.1
Major Components	1-4	3.3.1
Secondary Components	1-4	3.3.1
Internal Friction	1-4	3.4
Cohesion	1-5	3.5
Internal Friction and Cohesion	1-5	3.6
Capillarity	1-5	3.7
Compressibility and Elasticity.....	1-6	3.8
Permeability	1-6	3.9
Plastic Limit	1-7	3.10
Liquid Limit	1-7	3.11
Plastic Index	1-7	3.12
Figure 1-1 Water Effects on Soils	1-9	new
1.2 Classification of Soils and Soil-Aggregate Mixtures	1-10	4
Classification Procedures	1-10	4.1
Group Index	1-10	4.2
Examples	1-10	4.2.1
Graphical Method.....	1-11	4.2.2
Description of Classification Groups	1-11	4.2
Figure 1-2 Classification of Soils.....	1-13	4-1
Figure 1-3 Graphical Determination of Group Index	1-14	4-2

Section/Figure	Page	Old Section
1.3 Crude Soil Identification Techniques Used in the Field	1-15	new
Granular Soils	1-15	new
Fine Grained Soils (Silts and Clays)	1-15	new
1.4 Engineering Properties of Soils	1-16	new
Properties of Granular Soils	1-16	new
Properties of Fine Grained Soils	1-16	new
Properties of Silt	1-16	new
Properties of Clay as They Relate to Silt	1-16	new
Moisture Effects on Soils	1-16	new
Estimating Optimum Moisture	1-17	new



1.0 General Soils Information

1.1 Soil and Soil Properties

Each term used in soil work has specific meaning and application. Each soil test has specific meaning and application and indicates certain soil properties. Care in using correct terminology will prevent confusion and misunderstanding.

Soil

Soil is defined as follows by specifications: "All earth materials, organic or inorganic which have resulted for natural processes such as weathering, decay, and chemical action in which more than 35 percent by weight of the grains or particles will pass a 0.075 mm or 75mm (200) sieve.

Soils have properties that influence their behavior and value. The properties of soil will vary with its gradation (composition), its moisture content, its vertical position in relation to the surface of the ground, and its geographical location. The more common properties encountered and used in highway work are defined and discussed in this manual.

Most soils originally were solid rock. Time and climate have broken the rock into progressively smaller particles. This can be shown in the laboratory by taking two or three pieces of gravel or stone and pulverizing them. First, sand-size particles can be made, then silt-size particles and finally clay-size particles. However, as nature reduces rock into finer particles, chemical changes also take place; therefore, clay produced by nature over a period of many years will vary from clay-size material produced in a short time in a laboratory.

Soil Sizes

By naming and defining of sizes of the soil particles, all soil tests are placed on a common ground for comparison. The amount of soil retained or passing each sieve is one of the major tools used in judging, analyzing and classifying a soil.

The quantities of each are determined by a laboratory analysis that separates the soil into groups of particle sizes. The standard methods of test prescribed by AASHTO T 88 and ASTM D 422 have been used widely in highway engineering and are used by the Department.

These methods of test cover the quantitative determination of the distribution of particle sizes larger than 0.074 mm retained on the 75mm (200) sieve is determined by sieving, while the distribution of particle sizes smaller than 0.074 mm is determined by a sedimentation process, using a hydrometer to secure the necessary data.

Definition of sizes used by the Department are the same as established by AASHTO T 88, with the exception of the definition of clay, and are as follows:

- Boulders: larger than 203 mm (8 inches)
- Cobbles: 75-203 mm (3 to 8 inches)
- Gravel: passing 75 mm (3 inch) and retained on 2mm (No. 10) sieve
- Sand: passing 2 mm (No. 10) sieve and retained on 75mm (200) sieve
 - A. Coarse Sand: passing 2 mm (No. 10) sieve and retained on 425m m (No. 40) sieve
 - B. Fine Sand: passing 425m m (No. 40) sieve and retained on 75m m (200) sieve
- Silt: 0.074 mm to 0.005 mm
- Clay: smaller than 0.0005 mm

Texture

The amount of each soil type (i.e. boulders, cobbles . . . silt and clay) contained in a soil mixture will determine its texture or feel. Classification of soils by texture must not be confused with classification of soils for engineering purposes. Sometimes they are similar but at other times they may be different. The amount of each soil type in the soil sample is determined by laboratory tests. These test results then are compared with the definitions of texture in use to determine the texture name.

With laboratory experience in testing and classifying the texture of soil after its sieve size is determined, it is possible to make approximations of texture by the feel of moist soil when rubbed and ribboned between the thumb and index finger.

The texture of soil is given to tell as much as possible about a soil in a few words. With texture given, approximations and estimates can be made of many properties of a soil, such as bearing value, water-holding capacity, probability to frost-heave, permeability, etc.

Soil Components

It is the practice of the Department to describe soil components and texture of a soil as follows:

Major Components. Major components are described as gravel, sandy gravel, gravelly sand, sand, silty sand, clayey sand, sandy silt, silt, clayey silt, silty clay or clay. To classify as a major component, more than 35 percent of the total sample is required. Where two words are used to describe the major component, the second word describes the greater quantity. Examples: In silty sand, sand predominates; in sandy silt, silt predominates.

Secondary Components. Descriptions of secondary components are preceded by the term listed below, in accordance with the percent of total sample indicated:

Term	Percent of Total Sample
Trace	0-10
Little	10-20
Some	20-35
And	30-35

Examples of the texture descriptions for materials with components indicated, as determined by test results, are as follows:

- A. Sand 30%, silt 55%, clay 15% - sandy silt with a little clay.
- B. Sand 8%, silt 55%, clay 37% - silt and clay with a trace of sand.
- C. Gravel 2%, sand 12%, silt 42%, clay 38% - silt and clay with a little sand, trace of gravel.
- D. Gravel 20%, sand 68%, silt 12% - gravelly sand with a little silt.

Internal Friction

Internal friction is defined as the resistance to sliding within the soil mass. Gravel and sand impart high internal friction and the internal friction of a soil increases with sand and gravel content. For a sand, the internal friction is dependent on the gradation, density and shape of the soil particle, and is relatively independent of the moisture content. Clay has low internal friction, which varies with the moisture content. A power-dry, pulverized clay has a much higher internal friction than the same soil saturated with moisture, since each soil particle can slide on adjoining soil particles much more easily after it is lubricated with water.

Various laboratory tests have been devised to measure internal friction. It is defined as the angle whose tangent is the ratio between the resistance offered to sliding along any plane in the soil and the component of the applied force acting normal to that plane. Values are given in degrees. Internal friction values range from 0 degree for clay just below the liquid limit to as high as 34 degrees or more for a dry sand. A very stiff clay may have a value of 12 degrees. The governing test should be based on the most unfavorable moisture conditions that will prevail when the soil is in service. This "angle of internal friction" is not the same as the natural angle of repose or degree of slope on the soil in fills.

Cohesion

Cohesion is defined as the mutual attraction of particles due to molecular forces and the presence of water. The cohesive force in a soil will vary with its moisture content. Cohesion is very high in clay but of little or no significance in silt and sand. Power-dry, pulverized clay will have low cohesion. However, as the moisture content is increased, the cohesion is increased until the plastic limit is reached. Then the addition of more moisture will reduce the cohesion. By partially overdrying wet clay, most free water is removed and the remaining moisture will hold the clay particles together so firmly and give the soil such high cohesion that a hammer may be required to break the particles apart. These conditions are illustrated, respectively, by the dry dirt road in summer that dusts easily but carries large loads; the muddy, slippery road of spring and fall; and the hard-baked surface of a road immediately after summer rains.

Various laboratory tests have been devised to measure cohesion. Results are usually given in kPa (kilopascals), psf (pounds per square foot) of cross section and may vary from 0 psf in dry sand or wet silt to 96 kPa (2,000 psf) in very stiff clays. Very soft clays may have a value of 10 kPa (200 psf). The governing test should be based on the most unfavorable moisture condition that will prevail during service.

Internal Friction and Cohesion

The stability and hence the structural properties of soil are determined to a large extent by the combined effects of internal friction and cohesion. In most soils these combine to make up the shearing resistance. The combined effects are influenced by other basic factors such as capillary properties, elasticity and compressibility. All these factors and the site on which the soil is located determine the moisture content that will prevail in the soil in service. They also govern the load-carrying capacity of a soil, which is the primary concern. The clay-gravel road made up largely of gravel and sand,

with a small amount of silt to fill voids and a small amount of clay to give cohesion, illustrates a soil of high bearing value produced by high internal friction due to sand and gravel and high cohesion due to clay. Clay illustrates a soil of low bearing value because, when clay is wet, internal friction is negligible since no coarse grains are present and cohesion is low since it has been destroyed by moisture. The same clay, air-dry, will have high bearing value due to high cohesion brought about by the removal of moisture.

Capillarity

Capillarity is defined as the action by which a liquid (water) rises in a channel above the horizontal plane of the supply of free water. The number and size of the channels in a soil determine its capillarity. This soil property is measured as the distance moisture will rise above the water table by this action, and will range from 0 in some sand and gravel to as high as 9 meters (30 feet) or more in some clay soils. However, it often requires a long period of time for water to rise the maximum possible distance in clay soils because the channels are very small and frequently interrupted, and the frictional resistance to water is great in the tiny pores.

Moisture in silt soils may be raised by capillarity only 1 meter (4 feet) or so. The capillary pores are larger than for clay, a larger quantity of water is raised in a few days rather than over a long period. Silts are considered to have “high capillarity” by Highway Engineers because of this rapid rise of water. The capillary rise in gravels and coarse sands varies from zero to a maximum of a few centimeters (inches).

Complete saturation of the soil seldom occurs at the upper limits of rise of capillary moisture.

Capillarity of a soil and the elevation of the water table under the pavement determine whether the subgrade will become saturated in this manner. Whether or not the subgrade become saturated from capillary action (or from condensation, seepage, etc.) determines the bearing value of the soil to a considerable extent. Subgrade saturation by capillarity also determines

whether frostheave and similar occurrences in subgrade will create a problem requiring treatment for satisfactory performance in service.

Compressibility and Elasticity

Compressibility and elasticity are the properties of a soil that cause it to compress under load or compaction effort, and to rebound or remain compressed after compaction. Most soils are compressible. Silty Soils of the A-5 group are the most elastic of Ohio soils, and make poor subgrades for pavements. Fortunately A-5 soils are limited in occurrence in Ohio. The A-7 soils in Ohio are moderately elastic, but do not present special problems in embankment or subgrade. A-4 soils are elastic under some moisture conditions, and sometimes present problems of stability during construction, but provide adequate support for pavements where good design and construction practices have been followed. Details of these soil classifications are given in Section 1.2. When a measurement of the amount of elasticity of a soil is required, it is determined by special tests that simulate moisture changes and loading conditions anticipated in the field.

See Moisture Control of Soil Embankments During Construction in Chapter 3 for further explanation on elasticity.

Permeability

Permeability, a property of soil that allows it to transmit water, is defined as the rate at which water is transmitted by soils. It depends on the size and number of soil pores and the difference in height of water at the point where it enters the soil and the point where it emerges. It is determined by tests on a representative sample of soil and expressed as the coefficient of permeability, and it equals the velocity of water-flow in centimeters per second under a hydraulic gradient of 1. A hydraulic gradient of 1 exists when the pressure head (or height of water) on the specimen in centimeters divided by the depth of the specimen in centimeters equals

1.

The permeability of a soil varies with such factors as void ratio, particle size and distribution, structure and degree of saturation. Obviously, the permeability of a particular soil will vary with the degree of compaction since this influences the size of the soil pores. A particular soil loosely packed will be more permeable than the same soil tightly packed. Nature produces these same differences by freezing action in the surface in winter, loosening a soil; and by repeated wetting and drying in the summer, consolidating the soil, in connection with shrinkage forces that may be present.

The coefficient of permeability, k , is used to determine the quantity of water that will seep through a given cross section of soil in a given time and distance under a known head of water, by use of the formula.

$$k = \frac{QL}{HA t}$$

or

$$Q = \frac{k H A t}{L}$$

where

- Q** = quantity of water, in cubic centimeters;
- k** = coefficient of permeability, in centimeters per second;
- H** = hydrostatic head, in centimeters;
- L** = thickness of soil, in centimeters, through which flow of water is determined under hydrostatic head H;
- A** = cross sectional area of material, in square centimeters;
- t** = time, in seconds.

Tile can drain very porous soils, such as sands that have a k , in centimeters per second, of 1.0 to 10^{-3} (.001). Silty and clayey sand soils have a k of about 10^{-3} (.001) to 10^{-7} (.0000001). Highly cohesive clays have a k of less than 10^{-8} (.00000001). It is difficult, if not impossible, to reduce the water content of soils by tile drains when the permeability coefficient is less than about 10^{-3} (.001).

Generally speaking, for earth dams the U.S. Bureau of Reclamation classifies soil with k values about 10^{-4} (.0001) as pervious and soil with k below 10^{-6} (.000001) as impervious.

Plastic Limit

The plastic limit (P.L.) of soils is the moisture content at which a soil changes from a semisolid to a plastic state. This condition is said to prevail when the soil contains just enough moisture that it can be rolled into 3.18 mm (1/8 inch) diameter threads without breaking. The test, ASTM D 424 or AASHTO T 90, is conducted by trial and error, starting with a soil sufficiently moist to roll into threads 3.18 mm (1/8 inch) in diameter. The moisture content of the soil is reduced by alternate manipulation and rolling until the thread crumbles.

The plastic limit is governed by clay content. Some silt and sand soils that cannot be rolled into 3.18 mm (1/8 inch) threads at any moisture content. They have no plastic limit and are termed non-plastic. The test is of no value in judging the relative load-carrying capacity of nonplastic soils.

A very important change in load-carrying capacity of soils occurs at the plastic limit. Load-carrying capacity increases very rapidly as the moisture content is decreased below the plastic limit. On the other hand, load-carrying decreases very rapidly as the moisture content is increased above the plastic limit.

Liquid Limit

The liquid limit (L.L.) is the moisture content at which a soil passes from a plastic to a liquid state. The test, ASTM D 423 or AASHTO T 89, is made by determining, for a number of moisture contents, the number of blows of the standard cup needed to bring the bottom of the groove into contact for a distance of above 12.70 mm (0.5 inch). These data points are then plotted and the moisture content at which the plotted line (called flow curve) crosses the 25-blow line is the liquid limit.

Since the cohesion of soil retards flow, this test is an index of cohesion. Cohesion has been largely overcome at the liquid limit.

Sandy soils have low liquid limits of the order of 20. In these soils the test is of little significance in judging load-carrying capacity.

Silts and clays have significant liquid limits that may run as high as 80 or 100. Most clays in Ohio have liquid limits between 40 and 60.

High liquid limits indicate soils of high clay content and low load-carrying capacity.

Liquid limit can be used to illustrate the interpretation of moisture content as a percentage of the oven-dry weight of the soil. When a soil has a liquid limit of 100 (100 percent) the weight of contained moisture equals the weight of dry soil or, by weight, the soil at the liquid limit is half water and half soil. (Example: $w_c = 50/50 \times 100 = 100$.) A liquid limit of 50 shows that the soil at the liquid limit is two-thirds soil and one-third water. (Example: $w_c = 33/66 \times 100 = 50$.)

Plasticity Index

The plasticity index (P.I.) is defined as the numerical difference between liquid limit and plastic limit. The details of calculations are included in ASTM D 424 and AASHTO T 90. The plasticity index gives the range in moisture contents at which a soil is in a plastic condition. A small plasticity index, such as 5, shows that a small change in moisture content will change the soil from a semisolid to a liquid condition. Such a soil is very sensitive to moisture unless the silt and clay content combined is less than 20 percent. A large plasticity index, such as 20, shows that considerable water can be added to the soil before it changes from a semisolid to a liquid.

When the liquid or plastic limit cannot be determined or when the plastic limit is equal to or higher than the liquid limit, the plasticity index is considered to be nonplastic (N.P.).

The moisture conditions at the plastic limit and liquid limit, and the plasticity index, often are called the “Atterburg limits” (After Atterburg, the originator of the test procedures).

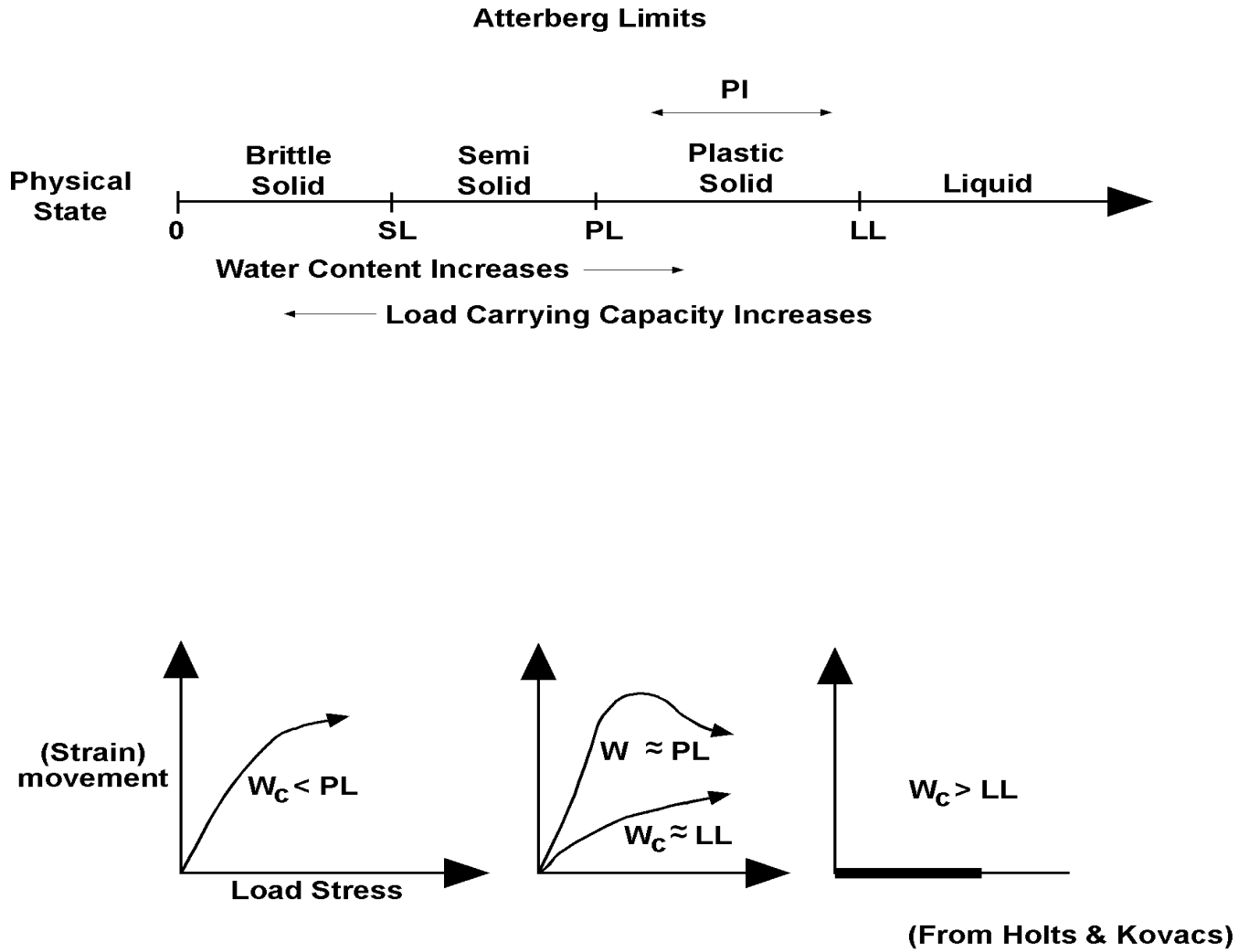

Figure 1-1. Water Effects on Soils

1.2 Classification of Soils and Soil-Aggregate Mixtures

Many varieties of soils having widely different physical characteristics are encountered throughout the State in the design and construction of highways. To simplify dealing with the soils encountered, the Department uses a classification system which is based on the AASHTO system of classification, with some modifications. The classification system used in Ohio is described in this section.

The Ohio classification system, which is a modification of AASHTO, utilizes a procedure for classifying soils into seven major groups, with several subgroups, based on laboratory determination of particle size distribution, liquid limit and plasticity index. Evaluation of soils within each group is made by means of a Group Index, which is a value calculated from an empirical formula. The group classification, including group index, is useful in determining the relative quality of the soil material for use in earthwork structures, particularly embankments, subgrades and subbases.

Classification Procedures

With required test data available, proceed from left to right in Figure 1-2 and the correct group will be found by process of elimination. The first group from the left into which the test data will fit is the correct classification.

Group Index

The AASHTO classification provides a means of evaluating soils within a group as well as between groups, referred to as the group index system. The system has been included in the Ohio classification chart without modification. Group indexes range from 0 to 20 and are computed by an empirical formula weighted to take into account the influence of variations in percentage of coarse material, liquid limit and plasticity index. Assuming good drainage and thorough compaction, the suitability of soils as subgrade materials is inversely related to the group

index, that is, the lower the group index, the higher the supporting value of the soil as a subgrade material. Thus a group index of 0 indicates a “good” subgrade material, and a group index of 20 indicates a “very poor” subgrade material. The group index is calculated from the following formula:

Group Index = $0.2a + 0.005ac + 0.01bd$ in which:

- a = That portion of percentage passing 0.075 mm (No. 200) sieve greater than 35 percent and not exceeding 75 percent, expressed as a positive whole number (1 to 40).
- b = That portion of percentage passing 0.075 mm (No. 200) sieve greater than 15 percent and not exceeding 55 percent, expressed as a positive whole number (1 to 40).
- c = That portion of the numerical liquid limit greater than 40 and not exceeding 60, expressed as a positive whole number (1 to 20).
- d = That portion of the numerical plasticity index greater than 10 and not exceeding 30, expressed as a positive whole number (1 to 20).

Examples

The following are examples of calculation of the group index:

1. Assume that an A-6 material 65 percent passing 0.075 mm (No. 200) sieve, liquid limit of 32 and plasticity index of 13. The calculation is as follows:
 - a = $65 - 35 = 30$
 - b = $55 - 15 = 40$ (55 substituted for 65, as critical range is 15 to 55)
 - c = zero, since liquid limit is below 40
 - d = $13 - 10 = 3$

Group index = $(.2 \times 30) + (.005 \times 30 \times 0) + (.01 \times 40 \times 3) = 7$ (Recorded to nearest whole number).

2. Assume that an A-7 material has 54 percent passing 0.075 mm (No. 200) sieve, liquid limit of 62 and plasticity index of 33. The calculation is as follows:

$$a = 54 - 35 = 19$$

$$b = 54 - 15 = 39$$

$$c = 60 - 40 = 20 \text{ (60 is substituted for 62, as critical range is 40 to 60)}$$

$$d = 30 - 10 = 20 \text{ (30 is substituted for 33, as critical range is 10 to 30)}$$

$$\text{Group Index} = (.2 \times 19) + (.005 \times 19 \times 20) + (.01 \times 39 \times 20) = 14.$$

Graphical Method

Charts for graphical determination of group index are shown in Figure 1-3.

Description of Classification Groups

1. Group A-1. The typical material of this group is a well-graded mixture of stone fragments of gravel, coarse sand, fine sand and a nonplastic or feebly plastic soil binder. However, this group includes also stone fragments, gravel, coarse sand, etc., without soil binder.
2. Subgroup A-1a includes those materials consisting predominantly of stone fragments or gravel, either with or without a well-graded soil binder.
3. Subgroup A-1b includes those materials consisting predominantly of coarse sand either with or without a well-graded soil binder.
4. Group A-3. The typical material of this group is fine beach sand without silty or clay fines or with a very small amount of nonplastic silt. The group includes also stream-deposited mixtures of poorly-graded fine sand and limited amounts of coarse sand and gravel. These soils are sometimes difficult to compact similar to the A-4 group. The fineness of the material and the silt fines make stabilization difficult. See the group A-4 group for further explanation.
5. Subgroup A-3a includes mixtures of coarse and fine sand with limited amounts of silt of low plasticity.
6. Group A-2. This group includes a wide variety of "granular" materials which are borderline between the materials falling in Groups A-1 and A-3 and the silt-clay materials of Groups A-4, A-5, A-6 and A7. It includes all materials containing 35 percent or less passing the 75m m (No. 200) sieve which cannot be classified as A-1, A-3 or A-3a, due to fines content or plasticity or both, in excess of the limitations for those groups.
7. Subgroups A-2-4 and A-2-5 include various granular materials containing 35 percent or less passing the 75m m (No. 200) sieve and with a minus 425m m (No. 40) portion having the characteristics of the A-4 and A-5 groups. These groups include such materials as gravel and coarse sand with silt contents of plasticity indexes in excess of the limitations of Group A-1, and fine sand with nonplastic silt content in excess of the limitations of Group A-3. A-2-5 soils are unsuitable embankment material under 203.08 because of its low weight, high optimum moisture, high L.L. and low P.I. and its propensity to sloughing in service.
8. Subgroups A-2-6 and A-2-7 include materials similar to those described under Subgroups A-2-4 and A-2-5 except that the fine portion contains plastic clay having the characteristics of the A-6 or A-7 group. The approximate combined effects of plasticity indexes in excess of 10 and percentages passing the 75mm (No. 200) sieve in excess of 15 is reflected by group index values of 0 to 4.
9. Group A-4. The typical material of this group is a nonplastic or moderately plastic silty soil usually having 75 percent or more passing 75mm (No. 200) sieve. The group includes also

mixtures fine silty soil and up to 64 percent of sand and gravel retained on 75mm (No. 200) sieve. The group index values range from 1 to 8, with increasing percentages of coarse material being reflected by decreasing group index values. The A-4 group soils are usually very difficult to compact and stabilize. Minimizing the water content to obtain the required density and stability usually works. It is not unusual nor is it a change in condition to have difficulty in stabilizing or compacting these soils. This condition should have been expected for this type material.

10. Subgroup A-4a contains less than 50 percent silt sizes, while subgroup A-4b contains more than 50 percent silt sizes. A-4b is only allowed 1.0m (3.0 feet) below subgrade elevation because of frost heave potential.
11. Group A-5. The typical material of this group is similar to that described under Group A-4, except that it may be highly elastic as indicated by the high liquid limit. The group index values range from 1 to 12, with increasing values indicating the combined effect of increasing liquid limits and decreasing percentages of coarse material. This soil is unsuitable by 203.08 for use as embankment material because of its elasticity.
12. Group A-6. The typical material of this group is a plastic clay soil usually having 75 percent or more passing the 0.075 mm (No. 200) sieve. The group includes also mixtures of fine clayey

soil and up to 64 percent of sand and gravel retained on the 75mm (No. 200) sieve. Materials of this group usually have high volume changes between wet and dry states. The group index values range from 1 to 16, with increasing values indicating the combined effect of increasing plasticity indexes and decreasing percentages of coarse material.

13. Subgroup A-6a contains material with plasticity index of 15 or less, and subgroup A-6b contains material with a minimum plasticity index of 16.
14. Group A-7. The typical material of this group is similar to that described under Group A-6, except that it has the high liquid limits characteristics of the A-5 group and may be elastic as well as subject to high volume change. The range of group index values is 1 to 20, with increasing values indicating the combined effect of increasing liquid limits and plasticity indexes and decreasing percentages of coarse material.
15. Subgroup A-7-5 includes those materials with moderate plasticity indexes in relation to liquid limit and which may be highly elastic as well as subject to considerable volume change. This soil is unsuitable by 203.08 because of its elasticity.
16. Subgroup A-7-6 includes those materials with high plasticity indexes in relation to liquid limit and which are subject to extremely high volume change.

OHIO DEPARTMENT OF TRANSPORTATION

General Classification	Granular materials (35 percent or less of total sample passing 75µm (No. 200))						Silt-clay materials (More than 35 percent of total sample passing 75µm (No. 200))							
	A-1		A-3(1)		A-2		A-4		A-5		A-6		A-7	
Group Classification	A-1-a	A-1-b	A-3	A-3 a	A-2-4	A-2-5	A-2-6	A-2-7	A-4 a	A-4 b	A-6 a	A-6 b	A-7-5	A-7-6
Sieve Analysis:						*				**			*	
Percent Passing:														
2mm (No. 10)	50Max		51Min	(2)										
425µm (No. 40)	30Max		10Max	(2)										
75µm (No. 200)	15Max	50Max	25Max	35Max	35Max	35Max	35Max	35Max	36Min(3)	50Min(4)	36Min	36Min	36Min	36Min
Characteristics of Percent Passing (No. 40)														
Liquid Limit	6Max		N.P.	6Max	40Max	41Min	40Max	41Min	40Max	41Min	40Max	40Max	41Min	41Min
Plasticity Index					10Max	10Max	11Min	11Min	10Max	10Max	11-15	16Min	11Min(5)	11Min(5)
Group Index	0	0	0	0	0	0	4Max		8Max		12Max	10Max	16Max	20Max
Usual Type of Significant Constituent Materials	Stone Fragment Gravel & Sand	Find Sand	Sand	Sand	Silty or Clayey Gravel or Sand				Silty Soils				Clayey Soils	
General Rating As Subgrade	Excellent to Good						Fair to Good							

Classification Procedure. With required test data available, proceed from left to right on chart; correct group will be found by process of elimination. The first group from the left into which the test data will fit is the correct classification.

- (1) The placing of A-3 before A-2 is necessary in the "left to right eliminate process" and does not indicate superiority of A-3 over A-2.
- (2) Minimum of 50 percent combined coarse and fine sand sizes.
- (3) Less than 50 percent silt sizes.
- (4) Fifty percent or more silt sizes.
- (5) P.I. of A-7-5 subgroup is equal to or less than L.L. Minus 30. P.I. of A-7-6 subgroup is greater than L.L. minus 30.

*These soils are not allowed by 203.08.

**Only allowed 3.0 below subgrade

—The higher the plastic index the greater the amount of clay.

—In general, the higher the liquid limit the lower the load carrying capacity.

Figure 1-2. Classification of Soils

Group Index = Sum on Vertical Scale
of Charts 1 and 2

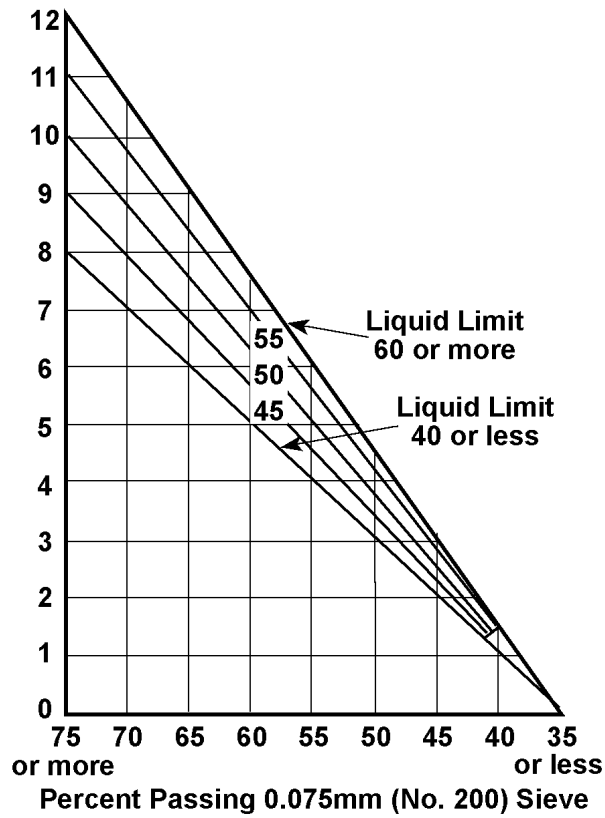

CHART 1

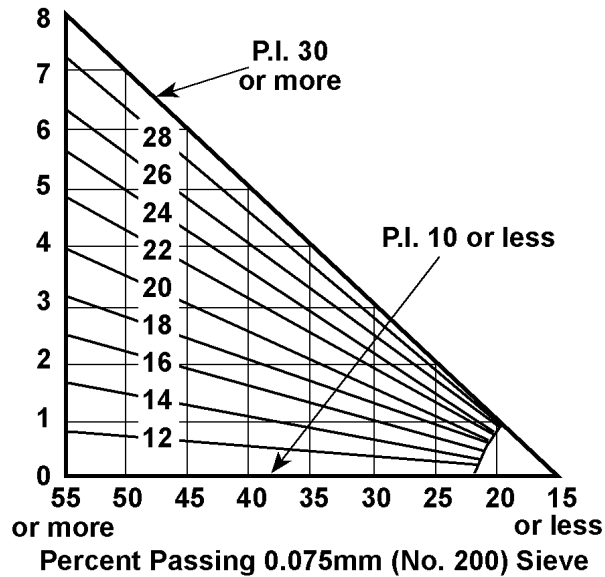

CHART 2

Figure 1-3. Graphical Determination of Group Index

1.3 Crude Soil Identification Techniques Used in the Field

It is sometimes necessary to make field decisions based on very little if any laboratory soils information or it may be necessary to verify the plan soil borings accuracy in the field. In these two cases above and certainly others it is important to have a basic understanding of how to crudely identify soils in the field. The following is some, but certainly not all, of the methods that can be used to identify soils in the field.

Granular Soils

Granular soils are easily identified by their particle size in the field. A sample may be taken inside and spread on a table to dry. A rough estimate of the material retained or passing each sieve may be obtained by examining the material when dry. The finer material cannot be separated and can only be distinguished between one another by a settling technique. This can be accomplished by using a hydrometer or by performing a crude settling test. This technique is beyond the scope of this manual.

Fine Grained Soils (Clays and Silts)

It is more important and harder to distinguish between a clay and a silt material in the field. Clays and silts should be treated and used differently in the field because their difference in engineering and compaction properties. See the properties of soils in next section.

A clay material can be easily rolled into a tread at moisture contents at, near or above the plastic limit of the material. Clays may often be rolled into 3mm (1/8 inch)

size diameter (about half the diameter of a pencil). See the plastic limit test earlier in this chapter for further information. The thread may be easier and may be rolled into smaller sizes as the clay content increases. You may not be able to roll a silt material into a 6mm (1/4 inch) tread no matter what the moisture content.

When clay is dry, it forms hard pieces that cannot be broken by hand pressure. Place an irregular piece of dry soil between the index finger and the thumb. Try to break the material. If the material is difficult or impossible to break, the material is probably a clay. A silt or sandy material will generally easily break with this hand pressure.

Clay fines are generally greasy, soapy and, sticky. A clay dries slowly. A silt will dry faster than a clay.

When performing these hand techniques you can observe the soil residue found on your hands for further information. If the soil on your hands is difficult to remove and the hands need rubbed briskly together to remove the soil, the material is probably a clay. A silt material is generally easily removed from the hands when rubbed together.

A silt material will react to vibration or shaking. Place a small amount of pliable soil in your hand. Hold the material in one hand and drop that hand on the other hand or a hard surface. Water will form on the surface of a silt material. You can also put the soil in a bowl and tap it on a table to get the same result. A clay will not react to this test.

The above crude identification techniques should not replace classification by the laboratory but only as a supplement. Send a sample to the laboratory for classification as soon as possible for verification.

1.4 Engineering Properties of Soils

The following are general statements regarding to the Engineering properties of soils that should be taken into consideration when dealing with problems in the field.

Properties of Granular Soils

1. Good foundation and embankment material.
2. Not frost susceptible if free draining.
3. Erodible material on side slopes of an embankment.
4. Identified by the particle size.
5. Easily compacted when well graded.

Properties of Fine Grained soils

1. Often have low strengths.
2. Plastic and compressible.
3. Lose part of their shear strength upon wetting or by disturbance.
4. Practically impervious.
5. Slopes are prone to slides (especially cut slopes).

Properties of Silt

1. High capillary action and frost susceptibility.
2. No cohesion and non-plastic when a pure silt.
(Some soils that are classified as silts but have a small amount of clay.)
3. Highly erodible.
4. Difficult to compact.
5. Release water readily when vibrated.
6. Acts like an extremely fine sand when compacted in the field.

Properties of Clay as They Relate to Silt

1. Better load carrying qualities.
2. Less permeable than silt.
3. Easier to compact than silt. Any soil is easier to compact than silt.
4. More volume change potential.
5. Plastic or putty-like property.
6. Clays are weaker when compacted wet of optimum.

Moisture Effects on Soils

Granular soils are less effected by the moisture content than clays and silts. Granular materials have larger voids and are fairly free draining. Granular materials have relatively larger particles as compared to silts and clays. They are (granular) by weight, heavy in comparison to the films of moisture which surround them.

Water content has a large effect on the physical properties of fine grained soils. The Atterberg limits are used to describe the effect of varying water contents on the consistency of fine grained soils. See Figure 1-1.

The PI is used to classify soils.

$PI = LL - PL$Liquid limits and plastic limit are the water content at the condition of the tests. (See Section 1.1)

The following is a brief description of the characteristics of soils in the physical states.

Liquid Soil State Characteristics

Highly saturated state.

Flows under its own weight.

No or very little friction between the particles.

Plastic Soil State Characteristic

Soil can be remolded into various shapes like modeling clay.

Semi-Solid Soil State Characteristics

No longer pliable.

Sample will crumble when rolled.

Brittle Solid Soil State Characteristic

Soil ceases to change volume due to the loss of water.

No real engineering application.

Liquid Limit - State between the plastic solid and the liquid state.

- At liquid limit of 100 the soil contains equal weights of soil and water.
- $W_c = W_w / W_s = 50/50$.
- At 50, the soil is 2/3 soil and 1/3 water..... $W_c = 33/66$.
- High liquid limit indicates soils of high clay content and low load carrying capacity.

Plastic Limit - State between semi-solid and the plastic solid.

- The soil condition when it contains just enough moisture to be rolled into an 1/8 inch diameter thread without breaking. Just starts to break up.
- Governed by the clay content.
- Greater the clay content the higher the plasticity, PI(LL-PL) and cohesiveness.
- Load carrying capacity increases rapidly as the moisture content decreases below the plastic limit.

Estimating Optimum Moisture

Most cohesive soils are compacted at a water content less than the plastic limit of the material. The optimum moisture is probably between the plastic limit and plastic limit minus 5. An estimate of the consistency of the material can be obtained by using the above information and looking at the water content of the soil from the soil borings before the work begins. Keep in mind the water content on the soil borings is the water content at the time of the borings. They should be considered an estimate of the actual condition.

You can approximate the optimum moisture of a material by the feel of the material in the field. Take a sample of the material in question in your hand. Squeeze the material together and let go of the material. If the

material falls apart when you release your hands, the material is probably dry of optimum. If the material stays together, the material may be at or above optimum. Spit on the material. If the spit beads up, the material is probably above optimum. If the spit slowly sinks in, the material is probably at optimum.

The above should only be used as an estimate and should not replace compaction testing. This estimate is different for each type of soil (clay, silt granular). These methods are used only as a guess of the material's optimum moisture only.

Notes



INDEX

Chapter 2.0 General Earthwork Construction

Section/Figure	Page	Old Section
2.1 Removal of Trees and Stumps	2-3	6
General	2-3	6.1
Policy	2-3	6.2
Trees Located Within the Work Limits	2-3	6.3
Trees Located Outside the Work Limits	2-3	6.4
2.2 Temporary Water Pollution, Soil Erosion and Siltation Control	2-5	9
General	2-5	9.1, 9.2.1
Specification Basis	2-5	9.2
Schedules and Methods	2-5	9.3
Erodible Conditions	2-5	9.4
Seventy-Thousand Square Meters (750,000 square foot) Limitation	2-6	9.5
Implementation of Requirements	2-6	9.6
Simplified Guidelines	2-7	new
Measurement and Payment	2-7	9.7
EPA Regulations	2-7	new
Minimum Standards for Pollution Controls as per the EPA Regulations	2-8	new
2.3 Borrow and Waste Areas	2-10	15
Purpose and Policy	2-10	15.1
Specification Basis	2-10	15.2
Principles and Procedures	2-10	15.3
Shrinkage	2-11	16
Causes of Shrinkage	2-12	16.2
Estimating Shrinkage	2-12	16.3
2.4 Elasticity and Deformation of Soils	2-13	11.3
2.5 Foundation of Embankments	2-15	7
Correction of Unstable Embankment Foundation	2-15	7.1
Sidehill Foundations	2-15	7.2
Figure 2-1 Swamp Treatment	2-16	7.1

Section/Figure	Page	Old Section
2.6 Proof Rolling Subgrade	2-17	13
Specification Basis	2-17	13.1
General	2-17	13.2
Soft Subgrade	2-17	12
Subgrade Correction Prior to Proof Rolling	2-18	13.3
When to Proof Roll	2-18	13.4
Selection of Load and Tire Inflation Pressures	2-18	13.5
Failure Criteria When Proof Rolling	2-18	new
Correction of Failed Areas	2-19	new
Figure 2-2 Load and Tire Inflation Pressures for Proof Rolling	2-20	13.1
2.7 Drainage	2-21	10



2.0 General Earthwork Construction

2.1 Removal of Trees and Stumps

General

The purpose of this section is to establish uniform practices to be followed for removal of trees and stumps. Where such removals are set up on a lump sum basis, varying interpretations as to the extent of removal are possible. It is necessary to exercise judgment in the administration of this item to accomplish the desired results.

Policy

It is the policy of the Department to remove only those trees which are necessary for construction and maintenance of the highway and for the safety of the traveling public. Special attention is expected in areas which are to become roadside parks.

Trees Located Within the Work Limits

Trees located within the work limits obviously must be removed because they interfere with construction. Trees of this type do not cause questions because they are to be removed unless the plans specifically provide otherwise.

Trees Located Outside Work Limits

Trees located outside work limits may require removal because of condition or possible hazard to traffic. Decision as to whether or not to remove trees of this type should be based on this section of the manual. The following principles apply generally to high speed highways. On local roads and roads within built-up

areas where relative slow speeds will prevail, desirable trees beyond the work limits should remain in place.

It is considered necessary to remove trees a minimum distance of 9 to 12 meters (30 to 40 feet) from the edge of the travel lanes, even though the construction limits do not extend that distance, for the protection of vehicles out of control. The reason for not having a definite distance is to permit the type of grading section and alignment to be taken into consideration as well as the condition of the tree. If the grading section is in cut with 3:1 backslope, or in fill with a depth of fill requiring a guard rail, it is not necessary to remove trees beyond the actual construction limits providing they are in good condition. If a tree within the right-of-way limits is dead, fallen, or unhealthy, it should be removed.

Where trees are allowed to remain in place beyond work limits, the area surrounding the trees should be cleared of undesirable undergrowth to provide an attractive appearance and to simplify maintenance. Some undergrowth is considered desirable from an aesthetic standpoint, and thus, should be left in place. Flowering trees and shrubs such as dogwood, redbud, hawthorn and other attractive growth, should be considered in this category. If there is any question regarding what is desirable or undesirable for the attractiveness of the roadside, the District Landscape Architect or Horticulturist should be consulted.

In addition to work limits as defined by the grading section, it may be necessary to remove some trees to permit fence to be placed. Such removal must be within the right-of-way limits and should not be greater than 3 meters (10 feet) in width in dense growth. Where trees



are scattered, the removal should be confined to trees which are in line of fence.

In removing trees through a heavily wooded section where a tree will remain on the right-of-way, the appearance of a mechanical cutting swath should be avoided. This can be accomplished by having a curved or irregular tree line defining the area rather than a straight line effect.

Where plan notes require the removal of all trees within right-of-way limits "Unless Marked by the Engineer to Remain," it is necessary to have a clear under-

standing of the policy since the specifications call for a definite determination of trees to be removed.

Markings for trees to remain in place should be of a temporary nature and not result in an undesirable appearance beyond the life of the contract.

The Engineer is encouraged to consider the recommendation of the District Landscape Architect or Horticulturist in tree removal, but it must be remembered the Engineer is in control of the work in accordance with the terms of the work in dealing with the Contractor.

2.2 Temporary Water Pollution, Soil Erosion and Siltation Control

General

It is the purpose of these specifications to establish uniform practices for applying the specifications for control of water pollution, soil erosion and siltation during and after construction and to control soil erosion to the maximum extent practicable by using reasonable and economical construction practices. Early seeding of slopes is the most effective erosion and siltation control that can be exercised. Full compliance with specification requirements must be secured on all projects. Preconstruction conferences and progress meetings provide opportunities to insure that these requirements are fully understood by both the Contractor and the Engineer. All plans have a storm water pollution control plan. The erosion control item locations are based on the final grades. Additions, deletions and relocations of these items should be proposed by the Contractor and approved by the Engineer.

Specification Basis

105.151 Borrow and Waste Areas; 203.05 Disposal of Excavated Material; 108.04 Limitation of Operations; 207 Temporary Water Pollution, Soil Erosion and Siltation Control; 104.06 Final Cleaning Up, and 659 Seeding and Mulching.

Schedules and Methods

1. The schedules and methods for accomplishment of temporary and permanent erosion control work are to be submitted with the progress schedule as prescribed in Section 108.04 of the Specifications must be specific about the plans and details for this work, including the following:

A. Show proposed location and details of interceptor ditches, dikes, dams, settlement basins, etc. The storm water pollution plan gives approximate locations

only. The actual locations should be proposed by the Contractor and approved by the Engineer.

B. Outline plans for stage seeding.

2. The progress schedule must show realistic scheduling of seeding coordinated with earthwork progress.

A. For example, for an average large earthwork project, it would not be acceptable for the progress schedule to show, at the end of a construction season, 85 percent of the earthwork completed and only 15 percent of the seeding completed. The percentage of seeding completed must be higher to accomplish the intent of the erosion control provisions of the contract.

3. A thorough review of the Contractor's proposed erosion control procedures should be made at the District level.

4. Information containing ideas and suggestions for installations to provide temporary and permanent erosion control has been made available to all Districts. District Construction Engineers should insure that all personnel responsible for administering these contract requirements are made aware of this information and provided a copy of these guidelines. Publications issued to the Districts are the following:

A. Implementation of Proper Erosion and Sediment Control Practices, Gayle F. Mitchell. This document contains all the pertinent information needed for this section and should be used by the Project personnel.

B. Booklet entitles "Suggestions for Temporary Erosion and Siltation Control Measures" published by the Federal Highway Administration, February, 1973.

C. Report No. 18, NCHRP synthesis of highway practice entitled "Erosion Control on Highway Construction" published by the Highway Research Board, 1973.

Erodible Conditions

1. Soils with high plasticity (A-6 and A-7) are less erodible than soils with low plasticity (A-1 through A-5).

Silty soils of A-4b classification and natural granular materials, particularly sand, are more susceptible to erosion than other Ohio soils.

2. Erosion is more severe on steep slopes than on gentle slopes. In general, erosion is not a problem on Ohio soils where slopes are 6 to 1 or flatter.

3. Rock and shale are not considered erodible materials.

Seventy-Thousand Square Meters (750,000 Square Foot) Limitation

1. The 70,000 square meters (750,000 square foot) limit applies separately to clearing and grubbing, and grading (excavation, borrow and embankment). The maximum area that could be underway at one time in erodible soils would be 70,000 square meters (750,000 square feet) of clearing and grubbing, and 70,000 square meters (750,000 square feet) of grading, unless modified in the bidding proposal or by the Engineer.

2. The Engineer can increase or decrease each 70,000 square meters (750,000 square foot) limit when project conditions such as soil conditions and/or Contractor operations indicate that a smaller or larger area is reasonable. On a long or complex project, the Contractor may have three separate grading units or Subcontractors in operation in which case it would be reasonable in some instances to apply the limit to each individual operation assuming finishing, mulching, seeding, etc., will closely follow the rough grading operations in each instance. In these cases the specified erosion control procedure could be applied to each individual operation.

3. The subgrade is not included in the 70,000 square meters (750,000 square foot) limitation for grading where the grades are under about 3 percent and where erosion probabilities are slight. On steeper grades or where the soils are highly erodible the 70,000 square meters (750,000 square foot) limit should include the subgrade area.

4. Where timber is removed by the earth is left generally undisturbed by the clearing operation, the area limitation need not be followed until grubbing operations begin.

Implementation of Requirements

1. Temporary and permanent erosion control features must be performed at the earliest practical time consistent with good construction practices. Temporary erosion control features, including temporary seeding, are meant to be supplementary measures and are not meant to be performed in lieu of permanent erosion control features included in the contract. Permanent seeding is performed between March 15 and October 15 in accordance with the requirements of Item 659 of the Specifications. Areas so seeded that are damaged through no fault of the Contractor prior to acceptance will be repaired in accordance with Item 659 of the Specifications.

2. The specifications now require that finishing and seeding operations closely follow the grading operation. It is the responsibility of the Engineer to determine when significant portions of the project can be seeded and to so notify the Contractor. Delay in accomplishing seeding for the reason that the Subcontractor for this work is committed elsewhere and is not available, is not acceptable. It is the prime Contractor's responsibility to make appropriate arrangements to perform this work in accordance with the specifications. When seeding and mulching of significant areas is not performed in stages as directed by the Engineer, work on earthwork items may be suspended until the exposed erodible areas are seeded and mulched. In accordance with 207.04, the Engineer may withhold progress estimates until proper control is achieved.

3. It is the responsibility of the Engineer to document the amount of erodible earth exposed both by clearing and grubbing and by grading. As the 70,000 square meters (750,000 square foot) limit for either operation

is approached, the Contractor should be notified and the fact documented. The Contractor has the responsibility to keep the amount of exposed, erodible soil within the specification limits or to request an increase in limits stating what measures he proposes to take which will minimize erosion and why it is justifiable to increase the limits. Any increase or decrease in the 70,000 square meters (750,000 square foot) limit granted by the Engineer must be documented in the project records. None of the above is meant to imply that at 70,000 square meters (750,000 square foot) area need be reached before erosion control measures are begun. If the Contractor exceeds the 70,000 square meters (750,000 square foot) limit, does not request an increase in area, or does not implement erosion control action as required by the specifications, earthwork operations may be suspended until the situation is corrected.

4. When suspension of earthwork items is considered necessary, the Contractor should be notified in writing, detailing the deficiencies and given specific instructions as to what action is necessary to bring the work within specification requirements. The Contractor should be given a definite time limit to correct the deficiencies before work is actually suspended.

5. If project conditions are such that it is impractical to perform either temporary or permanent seeding and mulching, other temporary control measures must be taken to insure control of eroded material. Installation of berm dikes, slope drains and additional siltation basins will be necessary until vegetative cover can be established.

Simplified Guidelines

The following is a guideline in simplified form that should be used to implement the as-directed items of the storm water pollution plan.

1. Do not place sediment basins, ditch checks or other similar controls in main crossing channels where most

of the area contributing flow is from off the project. Rock ditch checks may be used where necessary.

2. Place filter fabric fence at the toe of the slope normal to the slope direction where there is sheet flow going off the project or to a large existing or proposed channel.

3. Place sediment basins (or ditch checks for small areas) along or at the end of ditches before the main receiving channel. A series of smaller sediment basins is preferred over one larger basin.

4. Place filter fabric fence around catch basins, manholes, etc. where water enters a closed storm sewer system.

5. Stabilize large relocated channels immediately upon construction with permanent or temporary ditch protection and/or place rock checks.

6. Place dikes at the top of cut slopes with slope drains to keep flows from large off project drainage areas off cut slopes.

7. Apply sediment and erosion control features early and often on the construction project to prevent problems. Make adjustments as the field conditions dictate.

Measurement and Payment

It is the Department's responsibility at the project level to measure promptly and initiate estimates for payment to the Contractor for completed erosion control features such as benches, dikes, dams, sediment basins, etc.

EPA Regulations

The sediment and erosion control discharge is regulated by the Ohio EPA. A copy of a summary of the minimum standards for pollution controls follows. The pertinent regulation is in your sediment and erosion control manual by Dr. Gayle Mitchell. All construction projects greater than 5 acres are covered by this regulation. A permit is required 45 days prior to any construction activity. A copy of your storm water permit must

be displayed like a building permit. A copy of your weekly inspections must be available for inspection by the EPA. The corrections to the problems found during the inspection should be corrected immediately. See inspections in minimum standards for pollution controls and in the law.

The sediment and erosion control duties should be assigned to one individual on the project. The project personnel could be held personally liable for polluting the waters of Ohio.

The Ohio EPA may inspect the project at any time.

Minimum Standards for Pollution Controls

The following is derived and condensed from NPDES General Permit for construction activities. This section of the manual was given to the Department by OEPA personnel. We feel these are the items they would be looking for during their inspections. Subsections refer to the specific subsections in the regulations.

Subsections refer to the specific subsections in the regulations.

Part III 5.

b. Controls. ...shall develop a description of controls appropriate for the construction operation and implement such controls. ...*minimum components*:

i. Erosion and sediment controls.

A. Stabilization practices.

Preserve existing vegetation where attainable and revegetate disturbed areas as soon as practicable after grading as follows:

- Vegetate areas to remain dormant > 45 days within 7 days.
- Stabilize areas within 15 meters (50 feet) of any stream within 2 days on all inactive disturbed areas.
- Stabilize areas within 7 days after final grade on any portion of the site.

- Stabilize areas with mulch when conditions prohibit temporary or permanent seeding.

B. Structural practices.

The purpose of structural practices is to store runoff allowing sediments to settle and divert flows from exposed soils or limit runoff from eroding areas.

They are to control erosion and trap sediment from all sites remaining disturbed for more than 14 days.

They must be functional throughout earth disturbing activity.

- Implemented as the first step of grading and within 7 days from the start of grubbing and to function until area is restabilized.
- Pass concentrated storm water runoff from disturbed areas through a sediment settling pond. Capacity = 51 m³/ac or 51 m³/4,000m³ (67 yd³/ac) drainage area.
- Use sediment barriers to protect adjacent properties and water resources from sediment transported by sheet flow.
- Protect streams from sediment runoff.
- Prevent sediment from entering storm drain systems, unless the system drains to a settling pond.
- Divert runoff from disturbed areas and steep slopes.
- Stabilize channels and outfalls from erosive flows.

ii. Post-construction Storm Water Pollution Prevention.

Measures installed to control pollutants in storm water discharges that will occur after construction operation have been completed.

May include among others: infiltration of runoff; flow reduction by use of open vegetated swales and natural depressions and storm water retention and detention ponds.

- Place velocity dissipation devices at the outfalls of structures and along the length of any outfall

channel as necessary to provide a non-erosive flow velocity from the structure to a water course.

iii. Surface Water Protection.

If the project site contains any streams, rivers, lakes, wetlands, or other surface waters, certain construction activities at the site may be regulated under the Clean Water Act. Sections 404 and 401...

iv. Other Controls.

- A. Waste disposal. No solid or liquid waste shall be discharged in storm water runoff.
- B. Minimize off-site vehicle tracking of sediments.
- C. Comply with applicable State or local waste disposal, sanitary sewer or septic system regulations.

v. Maintenance.

All control practices shall be maintained and repaired as needed to assure continued performance of their intended function.

- Design pollution prevention plan to minimize maintenance requirements.
- Assure the continued performance of control practices.

vi. Inspections.

- Inspect erosion and sediment controls at least once every 7 days and within 24 hours after any storm event greater than 13 mm (0.5 inches) of rain per 24 hour period.
- Ascertain whether controls are adequate and properly implemented according to the schedule of operations or whether additional control measures are required.
- Inspect disturbed areas and storage areas for potential or evidence of pollutants entering the drainage system.
- Inspect discharge locations to ascertain whether controls measures are effective in preventing significant impacts to receiving waters.
- Inspect entrances and exits of site for evidence of off-site tracking.
- Maintain records of inspections.

Further information can be obtained by reviewing your training manual “Implementation of Proper Erosion and Sediment Control Practices” by Gayle E. Mitchell.

2.3 Borrow and Waste Areas

Purpose and Policy

The purpose of this section is to establish uniform practices for administering borrow and waste areas. It is the Department policy to approve requests to locate borrow and waste areas, providing the locations in no way adversely affect the highway and providing that the areas are restored in accordance with 105.151.

Material from outside the right-of-way used in embankment is considered to be borrow even though it is not paid for as borrow. Therefore, this section applies to all borrow and waste areas, including areas from which material is furnished and paid for under "203 Embankment," as well as areas from which material is furnished and paid for under "203 Borrow."

Specification Basis

105.151 Borrow and Waste Areas; 203.05 Disposal of Excavated Material; 207 Temporary Water Pollution, Soil Erosion and Siltation Control; and 104.06 Final Cleaning Up.

Principles and Procedures

Requests from the Contractor to locate borrow and waste areas shall be directed to the Engineer who shall either approve or disapprove the request. Action on each request shall be based on a study of information contained in the plan submitted by the Contractor, together with any supplemental information which is available to the Engineer. Specific considerations, which usually are made a part of the conditions for approval, include but not limited to the following:

1. For borrow and waste areas which will not become ponds when the work is completed:
 - A. The area shall be graded to assure positive drainage.
 - B. Restoration of all borrow and waste areas shall include cleanup, shaping, replacement of top soil, and establishment of vegetative

cover by seeding and mulching in accordance with 659 at no additional cost to the State.

2. For pits which will become ponds when the work is completed:
 - A. In general, ponds are not considered objectionable, and often are considered highly desirable by property owners and persons engaged in conservation of natural resources and wildlife. It is in general, the attitude of the Department of Natural Resources, and the Division of Wildlife of that Department, that the creation of additional ponds from borrow pits is desirable, providing they are constructed properly to void shallow stagnant water and are left in a condition to present a neat appearance.
3. Borrow Pit final grading:
 - A. The tops of the slope of the pit shall be at least 8 m (25 feet) from the highway right-of-way.
 - B. Borrow pit slopes adjacent to the highway shall be not steeper than 3 to 1, and all other borrow pit slopes is soil shall be not steeper than 2 to 1.
 - C. The borrow pit must be left in a condition satisfactory to the Engineer to blend with adjacent topography when the work is completed.
 - D. The stability of borrow and waste areas and any damage to surrounding property resulting from movement of the areas shall be the sole responsibility of the Contractor.
4. Wasting of Construction Debris:

Borrow and waste areas must comply with all the requirements of but not limited to the following Ohio EPA, Corps of Engineer, Local political sub division or zoning authorities. The wasting of Construction and Demolition Debris is governed by a new Demolition and Construction and Debris Law.

The law is governed by the OEPA or the local Boards of Health which ever has jurisdiction. The law governs the debris from construction sites that are not covered under solid or hazardous waste or other regulations.

By the EPA definition “Construction and demolition debris” (**debris**) is the material resulting from the alteration, construction, destruction, rehabilitation, or repair of any manmade physical structure. Those materials are those structural and functional materials comprising the structure and surrounding site improvements (e.g. fences, sidewalks). The definition identifies structures that are included and materials that comprise the structure which are considered debris. Any materials that are removed prior to demolition or are not part of the structure and surrounding site, will not be considered debris. Debris does not include materials identified or listed as solid wastes, infectious wastes, or hazardous wastes. The rule identifies other process materials (e.g. mining operations, nontoxic fly ash, etc.) that are not debris.

When the project encounters these materials the Project Engineer should consult the district environmental personnel for the current rules governing this law. A general interpretation follows:

The EPA is concerned with and the law covers two different types of debris:

1. Clean hard fill material such as asphalt millings, or portland cement concrete material (or mixtures of these materials with soil, aggregate etc.) coming from pavement or structural removal operations.
2. Debris such as wood, road metal, plaster, etc. in whole or mixed with clean hard fill. These items are usually associated with building debris.
 - Material No. 1 may be used as fill, recycled, or taken to an approved Construction and Demolition Debris Site.
 - No. 1 materials may be used for fill on or off the project provided the material is acceptable under the present specifications. If the material is

used as fill on an off site location the Local Board of Health or the OPEA needs a 7 day written notification from the Contractor before the material can be placed on the second site.

- No. 1 materials may be taken to a recycling operation for storage. Storage must be less than 2 years.
- No. 2 materials must be taken to an approved Demolition Debris site.

The legal removal and disposal of these materials are the sole responsibility of the Contractor. The project should monitor the Contractor’s work to minimize the Department future liability.

Approval of waste and borrow areas by the Engineer does not relieve the land owner or the Contractor of any other legal obligations regarding use of the waste and/or borrow area. This includes but is not limited to: Zoning requirements, Building permits, 404 Permits for wetland or stream fills, etc. In general, it is the Department’s position that waste areas located in wetlands will be discouraged due to the extensive requirements for avoidance and minimization of wetland fills during project development. Any problems or questions regarding the Environmental regulations should be forwarded to the Department’s Environmental personnel.

Shrinkage

Shrinkage refers to the apparent decrease in volume of the soil during the process of its removal from the cut or borrow and its placement in the embankment. As used in earthwork quantity calculations and adjustments for payment, in the following sections, a shrinkage factor is determined. The calculation for shrinkage follows: plan excavation used in embankment, plus actual measured borrow divided by plan embankment, plus excess fill. Considerable shrinkage may occur on projects which have a predominance of shallow cuts and deep top soil, while on projects which have deep cuts in bedrock, there may be little or no shrinkage.

Causes of Shrinkage

Shrinkage may be caused by one or more of the following:

1. Loss due to scalping.
2. Loss of material in hauling.
3. Settlement due to consolidation of the foundation under embankment load.
4. A greater density of the material in the fill than in the cut or borrow.

Estimating Shrinkage

Losses due to scalping of the cut and hauling of the material can be approximated on the basis of construction records of similar projects or new cross sections may be taken. Losses due to settlement of embankment foundation, in cases where the foundation is compressible, can be approximated on the basis of consolidation tests, settlement platforms and construction records of completed projects which are similar.

The amount of shrinkage resulting from increased density in the embankment material may be estimated on the basis of the average natural compaction in the cut or borrow and the average compaction for embankments constructed in Ohio or calculated with the average dry densities in the fill and cut or borrow. The

shrinkage resulting from increased density in the embankment may be computed by the following formula:

Shrinkage resulting from increased density in embankment =

$$\left[\frac{A}{B} - 1.00 \right] \times 100 = \textit{Shrinkage Factor}$$

Where: Shrinkage is expressed in percent.

A = Average percent compaction of the soil in the fills (Average compaction from 1938 through 1960 for 148,241 tests for all projects constructed in Ohio during this period = 100.6%).

B = Average percent compaction of the soil in the cut or borrow pit.

A may be the average dry density in the fill and B may be the average dry density in the borrow or cut also.

Judgment by the project personnel should be used for this shrinkage correction. See Section 10.2.

Example:

$$[\text{Borrow or cut}] \times \text{S.F.} = \text{Payment for Embankment}$$

The above equation could be used if the cross sections were taken in the borrow pit and not in the embankment for some reason. Check the specifications in this matter.

2.4 Elasticity and Deformation of Soils

When heavy rubber-tire construction equipment moves over an embankment layer of wet fine grained soil, some movement of the embankment surface occurs. One type of movement, called elastic movement, is described as follows: When the tire moves onto an area, the surface is deformed, and when the tire moves off the area, the surface rebounds, or springs back, with little or no rutting of the surface. Cracking of the surface may or may not occur following this type of movement, but cracking usually occurs in cases of pronounced elasticity. In the case of pronounced deformation there is displacement of some surface soil to each side of the tire, with resulting deformation, rupture, cracking and rutting. The magnitude of the elastic movement or deformation may depend on one or more of a number of factors, including the following: weight of equipment, size of tires, tire pressure, soil moisture, type of soil, depth of soil layer, and stability of material underlying the soil layer being observed.

Some elasticity and deformation of embankment is expected under loaded rubber-tire construction equipment. Moderate movement occurs under heavy equipment on embankments of satisfactory stability, and such moderate movement is not considered detrimental. Greater movement under very heavy equipment is likely to occur over embankment showing adequate stability under heavy equipment commonly used. Except for specialized situations, such as soft foundation soil at shallow embankment depth under the layer being observed, the greater movement due to the very heavy loads is not detrimental. In general, greater movement under very heavy loads should be permitted without increased restrictions on moisture control. It is not intended to use moisture control specifications to limit or restrict the use of very heavy construction equipment on embankment construction. It is the intent of the specifications to limit the moisture to obtain a stable embankment.

The amount of elasticity and deformation permissible under any given load varies with job circumstances. For example, for the first layer over soft original ground embankment foundation, considerable movement under loaded construction equipment is inevitable due to soft foundation material. The resistance to deformation is more critical in the top portion of embankment, near the subgrade, than in lower portions of the embankment. If the lower embankment layers are low stability material, such as wet silt, elasticity and deformation of the lower embankment layer being placed must be closely controlled. This would not be necessary if succeeding embankment layers were high stability material such as rock, shale, granular material or dry soil.

Equipment which can be used successfully to test for embankment stability includes the following: rubber-tire roller, grader, loaded scraper and loaded truck. Allowance must be made that more movement is to be expected under very heavy equipment than under heavy equipment ordinarily used in highway work. When items of rubber-tire construction equipment, such as scrapers, graders or rollers, are being used over the entire general area during normal embankment construction operations, and observation shows no area of questionable stability, it is not necessary to have a piece of testing equipment systematically cover the entire area for the specific purpose of observing stability. However, when the Engineer or Inspector questions or desires to check further the stability of an area during embankment construction, he is authorized to require the Contractor to move suitable equipment over the area for the purpose of checking for pronounced elasticity or deformation.

The determination of pronounced elasticity or deformation under the action of loaded rubber-tire construction equipment is based on the description given in the first paragraph of this section. The administration of this requirement should be tempered with sound judgment backed by construction experience. Decisions will be made at project level. Uniformity of application on



projects will be supervised closely by District Construction Engineers, and policy between Districts will be supervised by Staff and Field Engineers of the Bureau of Construction.

Moisture and compaction control are necessary and important to secure the satisfactory quality of embankments and subgrades essential for long life performance of pavements in a sound and smooth condition.

2.5 Foundation of Embankments

Occasionally foundation conditions are encountered which require treatment to secure stability beyond that specifically outlined by the specifications. Some examples of such unstable foundation conditions are:

1. Peat deposits,
2. Swampy area containing unsuitable organic soils at high water content,
3. Low lying, poorly drained areas with high water content,
4. Soil which is suitable when dry, but is unstable due to extremely high water content.

The nature and degree of instability of foundations encountered vary through a wide range of conditions. The treatment necessary to secure stability also varies depending on the condition of the foundation, the height of embankment and nature of embankment material available. See Elasticity and Deformation of Soils.

Correction of Unstable Embankment Foundation

The first step in determining the proper treatment for unstable foundations is to determine the nature of the foundation material, water content, location of free water, location of possible outlets for drainage, and depth and area extent of unstable material. For many unstable foundations, all or most of the needed information can be established by project personnel by means of test holes, rod soundings, and hand auger borings. Measures necessary to correct unstable foundations often are apparent when the cause and extent of the instability is known. Types of corrective measures which have been successfully used include the following:

1. Remove the unstable material and replace with suitable embankment material. This method

should be avoided for fills greater than 4m (12 feet). An initial thick lift should be tried first.

2. Drain wet areas. Consider using construction underdrains to drain these areas.
3. Require drying during a period of favorable drying weather,
4. Use an initial thick 0.3 to 1 m (1 to 3-foot) lift of soil, rock, or use granular material or material from pavement removal in the first layers of embankment. It is standard field practice to allow the Contractor to place this material without density controls to bridge the soft soils.

Corrective measures not covered by the plans or specifications must be initiated by established change order procedures. Figure 2-1 shows typical treatment in swamp areas.

Sidehill Foundations

Sidehill embankments present a unique problem in that they may be stable when originally constructed yet become unstable at a later date. The result is usually a landslide. In most cases, this is caused by water seeping into the embankment from the foundation.

Where sidehill embankments are to be constructed, special attention should be given to the foundation area. The plans and soil profile should be consulted to see where special benching, if any, is required; to see whether or not spring drains are provided, and to see if any potential spring or wet zones are mentioned. The foundation area should be inspected in detail for possible springs. In dry seasons, green or lush vegetation are often indicative of a semi-dormant spring that may become active during wetter weather. If spring zones are encountered and no spring drains are provided in the plans, they should be requested through established change order procedures.

TRENCHING AND BACKFILLING shall be carried progressively across the swamp and so coordinated as to leave an open trench not to exceed in length, of any time, the working reach of the equipment used for swamp excavation.

FILL shall be constructed by the method of end dumping, using granular material, up to the elevations designated on the plan. Embankment required above this elevation, if any, shall be constructed in accordance with 203.07 of the Construction and Materials Specifications.

EXCAVATION of unsuitable material ahead of the fill and end dumping of granular material across the bag area shall be advanced in a straight line for the full embankment width to avoid entrapment of unsuitable material beneath any portion of the fill.

GRANULAR MATERIAL, required for swamp treatment shall be specified as 203 Borrow using Granular Material, As Per Plan. The granular material shall meet the requirements of 203.02 of the Construction and Materials Specifications modified to require at least 75% by weight of the grains or particles to be retained on the No. 200 sieve.

EXCAVATED UNSUITABLE MATERIAL which is to be used adjacent to fills for slope flattening, or which is piled adjacent to the fill to be disposed of later in accordance with 203.05, shall be shaped to its final position or removed from the area at least two weeks prior to paving operations on the fill.

EQUIPMENT used for excavation of unsuitable materials shall be located ahead of the excavation unless otherwise authorized by the Engineer.

COST OF EXCAVATION OF UNSUITABLE MATERIALS between the limiting stations shall be included in the unit price bid for 203 Borrow Using Granular Material, As Per Plan, including the cost of excavation of unsuitable material. The granular material, used between the limiting stations as embankment above the original ground line, shall be paid for as 203 Borrow Using Granular Material, As Per Plan.

The quantity of granular borrow shall be determined in accordance with 203.15(e) of the specifications. The quantity of granular borrow, which does not include the cost of excavation, shall be the volume measured in final position by the end area method, plus 5% for compaction, using project cross sections. The quantity of granular borrow, including the cost of excavation of unsuitable material, shall be the total quantity of granular material as measured by 203.15(e) minus the quantity which does not include the cost of excavation, as determined above.

CROSS-HATCHED sections are included in quantities to allow for possible sloughing and undercutting.

*As shown on the Plans. (Excavation depth will usually be 5m (15 Ft.) Height of surcharge, if any, will be indicated on the plans.)

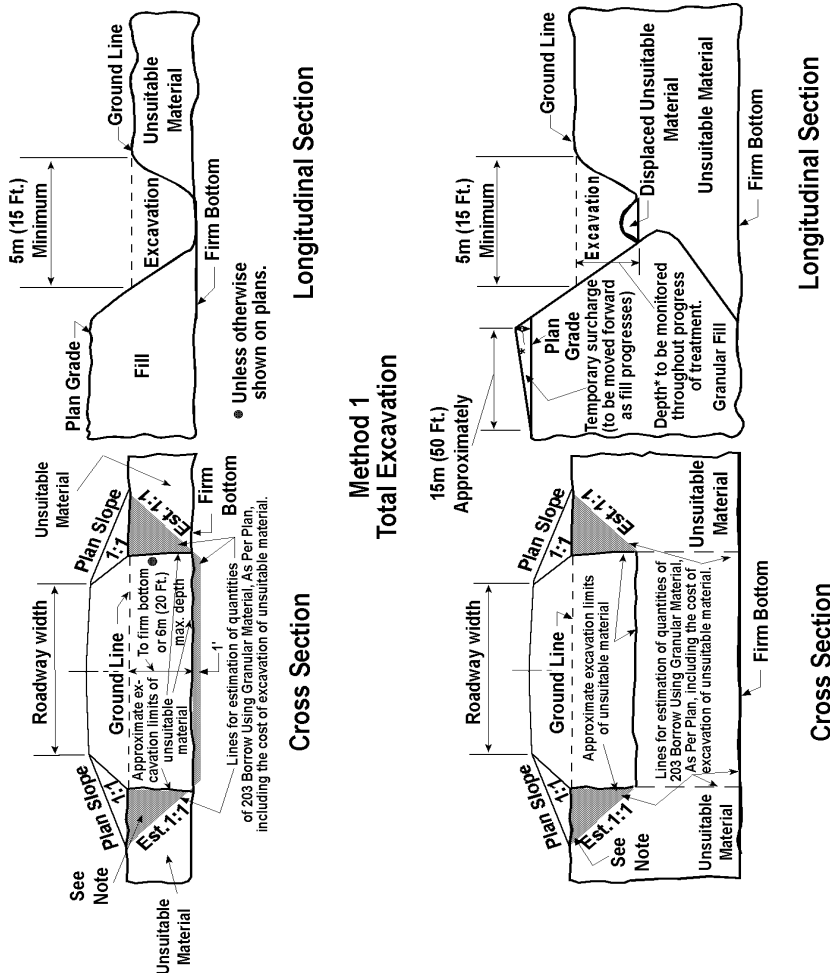

Figure 2-1. Swamp Treatment

2.6 Proof Rolling Subgrade

The purpose of this section of the manual is to provide information and guidance to project personnel to establish uniform practices for the use of a 23 to 45 metric ton (25 to 50 ton) roller for proof rolling subgrades on projects where such rolling is a requirement.

Specification Basis

Proof rolling shall be performed in accordance with 203.14 and paid for in accordance with 203.15 of the specifications.

General

The primary purpose of proof rolling subgrade is to locate soft areas. Soft subgrade areas that are located shall be corrected with the intent to secure uniform subgrade of adequate supporting capability.

For maximum effectiveness, proof rolling shall be done when the moisture content of the subgrade soils is near optimum or at the moisture content at which compaction was achieved. If the subgrade is too wet, the material will displace and rut. If the subgrade is too dry, it is possible that a dry hard surface crust may carry the proof roller over an undesirable soft wet underlying material without rutting or deflection, and the soft subgrade may not be detected.

In areas which have been undercut to replace the top portion of wet unstable soils, or in areas where reasonable subgrade stability has been obtained by drying the surface soils, excessive use of the fully loaded 45 metric ton (50 ton) roller may cause satisfactory subgrade to become unstable. One or two coverages usually are adequate to achieve satisfactory proof rolling results. Use only one coverage over deep wet soils, especially A-4 silty soils, in which instability may be caused by repeated rolling with a heavy load.

In view of the many variations which must be expected in dealing with Ohio soil and moisture conditions, the Engineer is given authority by specifications

to vary the number of passes and weight and tire pressure of the heavy roller to fit the conditions.

Close inspection throughout proof rolling is necessary in order to observe the effects of the rolling and to mark locations of soft subgrade for correction under provision of the specifications. Inadequate stability due to rolling is indicated by deflection, cracking or rutting of the surface of the subgrade.

Soft Subgrade

The specifications cover general procedures to be followed in correcting soft subgrade in “cuts.” As a guide to the Engineer’s judgment in correcting soft subgrades under the specifications, the following instructions shall be followed:

If soft subgrade is encountered in cuts due to no fault of the Contractor and subgrade stability cannot be secured by moisture control and compaction of the upper 0.3 m (12 inches), it shall be investigated for the cause. The investigation should be done quickly to expedite a decision on the corrective treatment necessary. Usually observation of heavy equipment operating on the subgrade and excavations into the subgrade 0.6 m to 1 m (2 to 4 feet) deep, using construction equipment or tools available on the project, and examination of the soil and moisture conditions thus exposed, will provide the information needed.

If the investigation indicates the need for removal of the material it shall be removed to the depth of the unstable material if the unstable material is less than 1 meter (3 feet) in depth or to 0.6 m (2 feet) if the unstable material is found more than 1 meter (3 feet) deep. A test length of the excavation filled with suitable material should be constructed. Experience has shown that most soft subgrade areas can be corrected in this manner by removal not more than 0.6 to 1 meter deep (2 to 3 feet). Only the most unusual cases require removal to depths greater than 1 meter (3 feet). If desired stability is not secured after processing a test section where removal was 0.6 to 1 meter (2 to 3 feet) deep, consider

ation should be given to securing a more stable backfill material, such as geofabric, geogrid, granular material, rock or material from pavement removal, rather than to additional depth of excavation.

These undercut areas do not need proof rolled but should be tested with a ± 14 metric tons (15 ton) vehicle to test stability.

The above investigation and undercut guidelines can be used as a guide to correct failed proof rolled areas also.

Subgrade Correction Prior to Proof Rolling

The Engineer shall observe the effect of heavy equipment operating on the subgrade at the time of rough grading. When rutting and deflection under heavy equipment shows the subgrade to be soft, correction shall be authorized by the Engineer at the time of rough grading. See Elasticity and Deformation of Soils.

Do not require that correction be delayed until later checked by proof rolling. Make the correction by excavating and disposing of soft subgrade, and replacing it with suitable material as provided for by the specifications.

When to Proof Roll

For areas where subgrade appears to be stable without undercutting, proof roll after the 0.3 m (12 inches) of the subgrade has been brought to specification requirements for moisture and density, and after the subgrade has been brought to approximate shape (within 30 to 60 mm) (0.1 foot to 0.2 foot) required by plan lines. The proof rolling should be done as soon after the regular compaction rolling as possible, before the subgrade has become too wet or dry for effective proof rolling. For areas which obviously are unstable and require undercutting, do not proof roll unnecessarily to demonstrate that subgrade correction is required.

Proof rolling may be done either before or after pipe underdrains are installed. If done after underdrains are installed, rolling should not be done directly over the

underdrains, but may be 0.3 to 0.6 m (1 to 2 feet) away from the underdrains because of the potential damage to the underdrains.

Subgrade under paved shoulders need not be proof rolled at the same time as the subgrade for the pavement, but may be checked later, after placing the pavement.

Section of Load and Tire Inflation Pressure

It is imperative that the project chooses the correct load for the right type soil or situation. These loads and tire pressures are soil type sensitive when looking at failure criteria.

Total load and tire pressure shall be 32 metric ton (35 tons) and 820 kPa (120 psi) except they may be varied by the Engineer within the limits provided in 203.14 and Figure 2-2.

But a general guideline follows:

- A. For A-4, A-6, and A-7 soils use a 32 metric ton (35 ton) roller with a tire pressure of 820 kPa (120 psi). This load and tire pressure should be used on most projects because these are the most common soils we have in the State of Ohio.
- B. For granular soils, and soil, rock and granular mixtures, use 46 metric ton (50 ton) roller with 1030 kPa (150 psi) tire pressure.
- C. Do not reduce the load or tire pressure less than 32 metric ton (35 ton) and 820 kPa (120 psi) in a fill section where the instability is not caused by a soft foundation.
- D. The goal of proof rolling is to maximize the load to point out the soft subgrade. These soft soils could be 1 to 2 meters (3 to 5 feet) deep.

Failure Criteria When Proof Rolling

The failure criteria for proof rolling is not as straightforward an answer as it might seem. There is no single answer that can fit all situations. The failure is based on experience and if there is any doubt the Construction Engineer should be consulted.

The following is the general criteria that can be used:

- A. Rutting in excess of 50mm (2 inches) should always be considered failure.
- B. Elastic movement or rutting with substantial cracking or substantial lateral movement of the soil should be considered failure.
- C. Rutting between 25-50 mm (1-2 inches) should be suspect but may be left in place.
- D. Rutting less than 25 mm (1 inch) should not be of a concern.
- E. This criteria should be modified in accordance with the type of roadway being constructed.

Correction of Failed Areas

Correction of these failed areas should be made similar to soft subgrade discussed earlier in this section. Do not proof roll after undercutting, but use 14 metric ton (15 ton) vehical to test the soil stability.

The minimum stability needed is the ability to pave the project. The failed areas in cut areas and shallow fills are the Department's responsibility. If the failure was caused by the fill it would be the Contractor's responsibility. The failed areas in fill locations are the Contractor's responsibility.

If the Contractor fails the subgrade due to using it as a haul road or due to his negligence it's his/her responsibility. We do not build subgrades for haul roads.

NOTE: Before proof rolling, correct all subgrade observed to be soft under heavy equipment during rough grading.

SOIL TYPE AND CONDITION		CUTS (& fills less than 0.3 m (1 ft.) in height)		FILLS (0.3m (1 ft.) or more in height)	
		Load metric tons (tons)	Tire Pressure (psi)	Load metric tons (tons)	Tire Pressure KPa (psi)
Granular Material (except A-3 sand)	A-1, A-2	45 (50)	(150)	45 (50)	(150)
Clean Sand	A-3	32 (35)	620 (90)	32 (35)	620 (90)
Silt and Sandy Silt	A-4	32 (35)**	620 - 1030 (90 - 150)	32 - 45 (35 - 50)	620 - 1030 (90 - 150)
Silt-Clay	A-6	32 - 45 (35 - 50)**	620 - 1030 (90 - 150)	32 - 45 (35 - 50)	620 - 1030 (90 - 150)
Clay	A-7	32 - 45 (35 - 50)**	620 - 1030 (90 - 150)	32 - 45 (35 - 50)	620 - 1030 (90 - 150)
Soil subgrade of good stability which trail shows will adequately support the 50-ton load, except for occasional small unstable areas.		45 (50)	1030 (150)		
Deep wet soils where adequate stability has been obtained by drying of the top part of the subgrade, and where instability may be caused by repeated rolling with a heavy load.		32 (35)**	620 - 1030 (90 - 150)		
Deep soft subgrade areas which have been corrected by excavation and replacement in accordance with 203.13(C).		32 (35)**	620 - 1030 (90 - 150)		

NOTE: In non-uniform areas not covered by the above instructions, use judgment to select a load that will best accomplish the results desired of test rolling.

* Identify soils based on field inspection and comparison with soil profile. Do not delay identification to secure laboratory test results for more accurate identification.

** Where subgrade is uniform and satisfactory but on the borderline of instability, and rolling with a heavy load would induce instability, use a 23 metric ton (25-ton) load. Only under unusual conditions should a load less than 32 metric tons (35 tons) be used for final test rolling.

Figure 2-2. Load and Tire Inflation Pressures for Proof Rolling

2.7 Drainage

Excess water in fine-grained soil is the principal cause of unstable soil conditions. The Engineer has a responsibility to take steps to secure adequate drainage where it is determined during construction the need exists. If investigation during construction indicates the need for underdrains not provided by the plans, a request for underdrains needed must be initiated by established change order procedures. Example of conditions which indicate the need for underdrains are:

1. Free water in the subgrade,
2. Saturated soils of moderately high permeability, such as sandy silt and silty clay of low plasticity.
3. Ground water seepage through layers of permeable soil.

In soft wet cut areas where the subgrade contains excess moisture, underdrains should be installed as early in the contract as possible consistent with the Contractor's plan of operation. Underdrains frequently will stabilize such areas and make undercutting unnecessary. However, the Contractor should not be required to delay any subsequent operations with the expectation that underdrains will correct a soft subgrade condition.

Additional underdrain placement is allowed to drain areas to be constructed on. These underdrains are not required to be functional after construction but only during construction. Construction underdrains may eliminate the need for under cutting.

Notes



INDEX

Chapter 3.0 Moisture Control and Testing

Section/Figure	Page	Old Section
3.1 Moisture Control of Soil Embankments During Construction	3-2	11
Specification Requirements	3-2	11.2
3.2 Test for Moisture	3-2	20
3.3 Nuclear Gauge Test for Moisture	3-3	20.8
Application	3-3	20.8.1
Description	3-3	20.8.2
Nuclear Equipment	3-3	20.8.3
Nuclear Test Procedures	3-3	20.8.4
Safety	3-3	20.8.5
3.4 Oven-Drying Method	3-5	20.2
Equipment	3-5	20.2.1
Procedure	3-5	20.2.2
3.5 Open-Pan Drying Method	3-6	20.2
Equipment	3-6	20.4.2
Procedures	3-6	20.4.3
Precautions	3-6	20.4.4
3.6 Alcohol-Burning Drying Method	3-6	20.5
Application	3-6	
Equipment	3-6	20.5.2
Procedure	3-6	20.5.3
3.7 Gasoline-Burning Drying Method	3-7	20.6
Application	3-7	20.6.1
Equipment and Procedure	3-7	20.6.2
3.8 Moisture-Density Curve Method	3-7	20.3
Procedures	3-7	20.3.2
Figure 3-1M C-88M Report on Compaction	3-8	new (20-1)
Figure 3-1 C-88 Report on Compaction	3-9	new (20-1)



3.0 Moisture Controls and Testing

3.1 Moisture Control of Soil Embankments During Construction

The purpose of this section is to establish uniform practices for applying the specifications for moisture control of soil embankments during construction.

Specification Requirements

The following requirement for moisture control is quoted from 203.11:

203.11 Moisture Control. “Embankment and subgrade material containing excess moisture shall be required to dry prior to or during compaction to a moisture content not greater than that needed to meet the density requirements, except that for material which displays pronounced elasticity or deformation under the action of loaded rubber tire construction equipment, the moisture content shall be reduced to secure stability. For subgrade material, these requirements for moisture shall apply at the time of compaction of the subgrade. Drying of wet soil shall be expedited by the use of plows, discs, or by other approved methods when so order by the Engineer.”

Experience has shown that to obtain the specification density, the moisture content must be at or near optimum. For some soils, particularly silty soils with low plasticity, may meet the moisture (± 3 percent from optimum) and compaction requirements but would have unsatisfactory stability. Some soils compact better and meet the density and stability requirements at minimum moisture (say -3 or more below optimum). The reason

for limiting the moisture contents for soil embankment this way is to insure stable embankments.

There is no numerical moisture requirement in the specifications. The Contractor must compact the material at a moisture content to obtain the density and stability of the material.

Moisture and compaction control are necessary and important to secure the satisfactory quality of embankments and subgrades essential for long life performance of pavements in a sound and smooth condition.

3.2 Test for Moisture

The specifications do not numerically limit the moisture content of embankment or subgrade soils. Moisture determinations must be made in the field to pick the required moisture-density curve and to control the Contractor's compaction operations. The following sections deal with various methods of determining moisture contents of soils.

For engineering purposes, moisture of soil is expressed in percent of dry weight.

Most of the time the moisture of a soil should be obtained by using the nuclear gauge readings. But there are situations that dry methods can and should be used. For each drying method the soil to be tested should be a representative sample of a least 1/2 kg (1 pound). The soil should be placed in a small, clean can or jar and covered with a tight lid at the construction site, to prevent evaporation of moisture while moving to the location of the test. The test should be conducted as

soon as possible after taking the sample. Location where sample is taken must be noted.

All the moisture tests should be checked against each other to ensure the accuracy of the moisture testing.

3.3 Nuclear Gauge Tests for Moisture

Application

Moisture content of soils can be determined by nuclear equipment designed for this purpose.

The nuclear method is the preferred method to obtain moisture content of soils. The nuclear gauge moisture may be used as the proctor moisture if the proctor is taken at the same time as the nuclear gauge readings, and it is representative of the soil tested.

Description

Nuclear gauges are nondestructive testing devices using the neutron energy absorption technique to measure the moisture content of rock or soil materials. Nuclear tests for moisture and density are detailed in the AASHTO - T-238.

The nuclear method for measuring the moisture content of soil and rock materials is based on the principle of measuring the slowing of neutrons emitted into the soil from a fast-neutron source. The energy loss is much greater in neutron collisions with atoms of low atomic weight, and is directly proportional to the number of such atoms present in the soil. The effect of such a collision is to change a fast neutron to a slow neutron. Hydrogen, which is the principal element of low atomic weight found in soils, is contained largely in the molecules of water in an inorganic soil. The number of slow neutrons detected by a counter tube, after emission of fast neutrons from a radioactive source, is counted electronically on a scaler. The count obtained on the scaler is proportional to the amount of water in the soil or rock.

Nuclear Equipment

The Department has in use nuclear equipment manufactured by Troxier Laboratories. Presently the

Department has the 3440 series gauges. Each gauge consists of a scaler, automatic timer, nuclear source, and detector tubes all contained in a single unit. These gauges measure moisture by the backscatter method, and density by either the backscatter or direct transmission method.

Nuclear Test Procedures

Specific instructions for the operation of each type of instrument in use by the Department are given in manuals prepared by the manufacturer of the instrument. The general procedure is somewhat similar for all types of gauges. See Chapter 6 on the procedure for using nuclear equipment for more detailed information.

Moisture Test. Determine the moisture using a Troxler 3440 gauge and record this information on the C-135B-M (C-135B).

Safety

There is no radiological danger to an operation of a nuclear gauge so long as the correct operating and safety rules are followed. Each operator is issued a specific set of instructions governing safety when the gauge is assigned to him. General safety rules governing the use of this equipment are as follows:

1. Never attempt to repair the gauge or open it to look inside. Any repairs to the gauge are to be done by a Central Office technician, or the manufacturer.
2. All operators or persons frequently in contact with nuclear gauges are required to wear film badges. These badges are to be sent to the Office of Material Management, Central Laboratory each quarter, where they are collected and forwarded to a film badge service company which determines and reports the dose, which is the quantity of radiation absorbed.
3. All gauges will be leak tested every 6 months.



4. If the gauge is damaged by construction equipment, do not move it from the area. Keep all people away from the gauge and notify the District Radiation Safety Officer then the Central Office Department's Radiation Safety Officer, at 614-275-1300.
5. If a gauge is lost or stolen, notify the State Highway Patrol and the Department's Radiation Safety Officer.
6. When not in use, all gauges must be secured with locks provided for this purpose and placed in the project field office or other approved storage area. They shall not be stored overnight in a vehicle.

3.4 Oven-Drying Method

This method of determining moisture content is applicable to all types of soils. The time required to dry the sample depends on the size and moisture content of the sample and the type of soil.

Equipment

1. Two-burner stove. Either an oil stove or a camp stove using white gasoline.
2. "Boss 75" portable oven, or equivalent. This oven measures approximately 0.5 m (20 inches) high, 0.5 m (20 inches) wide and 0.3 m (13 inches) deep. It sets on and is heated by the stove.
3. Several baking pans approximately 300 x 200 x 63 mm (12 x 8 1/2 x 2 1/2 inches).
4. Masonry trowel or putty knife.
5. Can of fuel. Can has tight stoppers and if it's used for gasoline it is painted red.
6. Scale of 12 kg (25-pound) capacity sensitive to 1 gram (.01 pound).
7. Piece of flat glass or pieces of bond paper with texture similar to the compaction forms.

Procedure

1. Weigh the pan to the nearest 1 gram (.01 pound). Record the weight.
2. Place approximately 0.5 kg (1 pound) of representative sample of wet soil in the pan on the scale. Record the combined weight.
3. Break up all lumps of soil with the putty knife or trowel and avoid any loss of the sample.
4. Place the pan with sample in the oven with the stove on.
5. Stir the soil every 3 to 5 minutes.
6. After the soil has changed to a lighter color and appears to be dry, remove the soil

sample from the oven and test to determine if it is completely dry by using one of the following methods:

A. Lay a piece of bond paper approximately 50 x 75 mm (2 x 3 inches) on the sample. If the paper curls immediately when laid on the sample, the soil contains moisture. The paper used for this test must be bond of hard surface texture like the paper used for the compaction forms.

B. Hold a piece of clean glass or a mirror in a horizontal position about 25 mm (an inch) above the soil sample. If the glass steams up, this is an indication of further moisture in the sample. Keep the glass away from the heat of the stove or direct rays of hot sun prior to the test since this test depends upon condensation of moisture in the hot air onto the cooler glass.

7. If the test indicates further moisture is in the sample, stir the sample and continue drying. Test the soil every 3 to 5 minutes until the test indicates the soil is dry.
8. Weigh the dried sample and pan to the nearest 1 gram (.01 pound). Record this weight.
9. Subtract the weight of the pan from the weight of pan and dry sample to obtain the weight of the dried sample.
10. Subtract the weight of the dried sample from the weight of the wet sample. This is the weight of water in the original sample.
11. Divide the weight of the water by the weight of the dried sample. Multiply this result by 100. This gives the percentage of moisture in the sample. The equation is:

$$\frac{\text{weight of wet soil} - \text{weight of dry soil}}{\text{weight of dry soil}} \times 100 = \text{Percent of Moisture}$$

3.5 Open-Pan Drying Method

This method is quick and simple, and gives accurate results for granular material. This method should not be used for fine grained soils (silts or clays) because the high temperatures may burn away the organic material if they were present. This method can be used for fine grained soils where limited accuracy is satisfactory and approximate moisture results are acceptable.

Equipment

1. Scale of 12 kg (25-pound) capacity sensitive of 1 gram (.01 pound).
2. Several baking pans approximately 300 x 200 x 63 mm (12 1/2 x 8 x 2 1/2 inches).
3. Two-burner stove burning white gasoline.
4. Putty-knife or other device for breaking up and stirring the soil.
5. Piece of flat glass or pieces of hard surface bond paper with texture similar to the compaction forms.

Procedure

Follows steps outlined for oven drying in Section 3.4 (1) through (11) except place the pan directly over the burning instead of in the oven.

Precautions

The following precautions should be taken to avoid introducing errors into the test:

1. Avoid overheating the soil. Use two pans, one inside the other, to avoid hot spots which may occur when a single pan is used.
2. Avoid baking the soil. Baking can be prevented by testing the material with a paper or glass test at sufficiently close intervals so that further heating can be discontinued after all the moisture has been evaporated.
3. Insure that no soil is lost during the test.

3.6 Alcohol-Burning Drying Method

Application

This method is quick and simple, and the alcohol burns at a low enough temperature 140°C to 160°C (286 F to 320 F) that it can be used with accuracy for most soil types. This method should be done outside or in a well ventilated area.

Equipment

1. Scale of 12 kg (25-pound) capacity sensitive to 1 gram (.01 pound).
2. Pan or can with perforated bottom and filter paper to fit bottom. (A 300 ml (10-ounce) round sample can is suitable for this purpose.)
3. 300 x 200 x 63 mm (12 x 8 1/2 x 2 1/2 inch) baking pan.
4. Glass stirring rod.
5. Supply of alcohol in tight can.

Procedure

1. Weigh perforated pan or can with filter paper in the bottom. Record weight.
2. Place sample of wet soil in perforated pan or can; weigh and record weight.
3. Place perforated pan or can in larger pan and stir alcohol into the soil sample with a glass rod until the mixture has the consistency of a thin mud or slurry. When stirring, do not disturb the filter paper on the bottom. Clean the rod.
4. Ignite the alcohol in the outer pan and in the sample and burn off all alcohol.
5. Repeat the process three times, or until successive weighings indicate no reduction in weight, after each burning .
6. After final burning, weigh perforated pan or can and dry soil, and record weight. The weight of dry soil equals this weight minus weight of perforated pan or can and filter.
7. Calculate moisture content as shown in Section 3.4.

3.7 Gasoline-Burning Drying Method

Application

This method is a quick and simple method of drying. However, the gasoline burns at such high temperature that it should be used only to dry granular materials. This method should only be used outside.

Equipment and Procedures

This method of drying is similar to the alcohol drying method with the exception that the perforated pan and filter are not used. The gasoline can be mixed with the sample in the baking pan and burned in the pan. Except for this, the test is run exactly the same as the alcohol burning method, described in Section 3.6.

3.8 Moisture-Density Curve Method

This method is satisfactory for fine grained soils such as clay or silt, but should not be used for granular materials because of the difficulty of obtaining accurate penetration resistance readings.

Soil must be screened through a 4.75 mm (No. 4) sieve before placing the material in the proctor mold when using penetration resistance to find moisture content. This method is not recommended and should be used as a last resort.

Procedure

Follow steps outlined by lines 4 through 12, Form C-88 M (C-88), Figure 3-1 M (3-1) and the applicable instructions in Chapter 7.

C-88-M
C-88-M
1/96

STATE OF OHIO
DEPARTMENT OF TRANSPORTATION

REPORT ON COMPACTION

Sample ID: 5555555-01 Personnel ID: 000-0000-000 Date Sampled: 11/11/89
 Type of Inspection: COMPACTION Producer Code: 55555-01 Contractor: COMPLETE GENERAL
 Material Code: 20321001 Test Results: PASSED

Project/P.O.	P.O. Ind.	Item Code	Ref. Number	Item Code	Ref. Number
<u>22(96)</u>		<u>203</u>	<u>112</u>		

Test of (check which): Embankment Subgrade Base Other _____ Min. Compaction Req.: 100 %
 From Sta 1 + 000 at 5 meters (ft) (or ft.) of centerline, at approx. Elevation 50 m

Read: "Manual of Procedures for Earthwork"

1. Weight of wet soil (& stone, if any) from auger hole + weight of container _____ 1. = 3.552 kg
2. Weight of container _____ 2. = 0.776 kg
3. Weight of wet soil (& stone, if any) from auger hole (#1 less #2) _____ 3. = 2.776 kg
4. Weight of 0.000943 m³ compacted wet soil + weight of container _____ 4. = 6.119 kg (Water Added)
5. Weight of 0.000943 m³ container _____ 5. = 4.359 kg 6.310
6. Weight of 0.000943 m³ compacted wet soil (#4 less #5) _____ 6. = 1.760 kg 4.359
7. Density of compacted wet soil (1060 X #6) _____ 7. = 1866 kg/m³ 1.951
8. **Average penetration reading (3 or more tests) using 32.26 mm² needle _____ 8. = - N 2.068
9. **Average penetration resistance (#8 ÷ end area of needle) _____ 9. = - MPa 178
10. Optimum moisture from Dry Weight Curve (Curve No. M) _____ 10. = 15.8 % 5.516
11. Moisture from Wet Weight Curve (Curve No. M) or by drying _____ 11. = 9.8 %
12. Amount above or below optimum moisture (difference #10 & #11) _____ 12. = 6.0 %
13. Weight of sand + weight of density-cone apparatus _____ 13. = 8.355 kg
14. Weight of density-cone apparatus _____ 14. = 2.100 kg
15. Weight of sand in density-cone apparatus (#13 less #14) _____ 15. = 6.255 kg
16. Volume of density-cone apparatus (recorded on density-cone) _____ 16. = 0.004332 m³
17. Density of sand (#15 ÷ #16) _____ 17. = 1444 kg/m³
18. Weight of density-cone and remaining sand after cone is filled on leveled area _____ 18. = 7.353 kg
19. Weight of sand required to fill cone on leveled area (#13 less #18) _____ 19. = 1.002 kg
20. Weight of density-cone and remaining sand after filling auger hole & cone _____ 20. = 4.336 kg
21. Weight of sand in auger hole and cone (#18 less #20) _____ 21. = 3.017 kg
22. Weight of sand in auger hole (#21 less #19) _____ 22. = 2.016 kg
23. Volume of auger hole (#22 ÷ #17) _____ 23. = 0.00140 m³
24. Density of wet soil in fill (#3 ÷ #23) _____ 24. = 1983 kg/m³
25. Density of dry soil in fill [(100 x #24) ÷ (100 + #11)] _____ 25. = 1806 kg/m³
26. Max dry density (From Curve No. M) _____ 26. = 1794 kg/m³
27. Compaction (#25 ÷ #26 x 100) _____ 27. = 100.7 %
28. Weight of Sample (#3) _____ 28. = _____ kg
29. Weight of stone removed from sample and retained on 19.0 mm or 4.75 mm sieve _____ 29. = _____ kg
30. Percent stone in sample (#29 ÷ #28 x 100) _____ 30. = _____ %
31. Weight of stone in one cubic meter of material (#24 x #30 ÷ 100) _____ 31. = _____ kg
32. Volume of stone in one cubic meter of material [#31 ÷ (Sp. Gr.* x 1000)] _____ 32. = _____ m³
33. Volume of wet soil in one cubic meter of material (1.00 less #32) _____ 33. = _____ m³
34. Weight of wet soil in one cubic meter of material (#24 less #31) _____ 34. = _____ kg
35. Density of wet soil (#34 ÷ #33) _____ 35. = _____ kg/m³
36. Density of dry soil [(#35 x 100) ÷ (#11 + 100)] _____ 36. = _____ kg/m³
37. Compaction with stone removed (#36 ÷ #26 x 100) _____ 37. = _____ %
38. Moisture from zero air voids curve using (#25 or #36) _____ 38. = 18.0 %

*Average Specific Gravity Values: Limestone = 2.6; Gravel = 2.5; Sandstone and Sandy Shale = 2.2
 **Use this method only as a last resort.
 ***Use 4.75 mm sieve for penetration method only.

Does material tested meet specification requirements for: (write yes or no on each of following)
 Max. dry weight YES; Moisture YES; Compaction YES
 Does test check zero air voids curve (check which): Yes No
 Action taken by (check which): Inspector or Project Engineer
 If material tested does not meet specification requirements:
 Additional rolling ordered Aerating ordered Watering ordered Other _____
 Computed By R. J. Putts Checked By Mike Jordan
 DOT-1636

Figure 3-1M. C-88-M Report on Compaction

C-88 C-88
1/96

STATE OF OHIO
DEPARTMENT OF TRANSPORTATION

REPORT ON COMPACTION

Sample ID: 55555555-01 Personnel ID: 000-0000-000 Date Sampled: 11/11/89
 Type of Inspection: COMPACTION Producer Code: 55555-01 Contractor: COMPLETE GENERAL
 Material Code: 203 21007 Test Results: PASSED

Project/P.O.	P.O. Ind.	Item Code	Ref. Number	Item Code	Ref. Number
<u>22(96)</u>		<u>203</u>	<u>112</u>		

Test of (check which): Embankment Subgrade Base Other _____ Min. Compaction Req.: 100 %
 From Sta _____ + _____ at _____ feet _____ (rt. or lt.) of centerline, at approx. Elevation _____ ft

Read: "Manual of Procedures for Earthwork"

1. Weight of wet soil (& stone, if any) from auger hole + weight of container _____ 1. = 7.83 lb
2. Weight of container _____ 2. = 1.71 lb
3. Weight of wet soil (& stone, if any) from auger hole (#1 less #2) _____ 3. = 6.12 lb
4. Weight of 1/30 ft³ compacted wet soil + weight of container _____ 4. = 13.49 lb
5. Weight of 1/30 ft³ container _____ 5. = 9.61 lb
6. Weight of 1/30 ft³ compacted wet soil (#4 less #5) _____ 6. = 3.88 lb
7. Density of compacted wet soil (30 X #6) _____ 7. = 116.4 lb/ft³
8. **Average penetration reading (3 or more tests) using 1/20 in² needle _____ 8. = - lb
9. **Average penetration resistance (#8 ÷ end area of needle) _____ 9. = - lb/in²
10. Optimum moisture from Dry Weight Curve (Curve No. M) _____ 10. = 15.8 %
11. Moisture from Wet Weight Curve (Curve No. M) or by drying _____ 11. = 9.8 %
12. Amount above or below optimum moisture (difference #10 & #11) _____ 12. = 6.0 %
13. Weight of sand + weight of density-cone apparatus _____ 13. = 18.42 lb
14. Weight of density-cone apparatus _____ 14. = 4.63 lb
15. Weight of sand in density-cone apparatus (#13 less #14) _____ 15. = 13.79 lb
16. Volume of density-cone apparatus (recorded on density-cone) _____ 16. = 0.153 ft³
17. Density of sand (#15 ÷ #16) _____ 17. = 90.1 lb/ft³
18. Weight of density-cone and remaining sand after cone is filled on leveled area _____ 18. = 16.21 lb
19. Weight of sand required to fill cone on leveled area (#13 less #18) _____ 19. = 2.21 lb
20. Weight of density-cone and remaining sand after filling auger hole & cone _____ 20. = 9.56 lb
21. Weight of sand in auger hole and cone (#18 less #20) _____ 21. = 6.65 lb
22. Weight of sand in auger hole (#21 less #19) _____ 22. = 4.44 lb
23. Volume of auger hole (#22 ÷ #17) _____ 23. = 0.0493 ft³
24. Density of wet soil in fill (#3 ÷ #23) _____ 24. = 124.1 lb/ft³
25. Density of dry soil in fill [(100 x #24) ÷ (100 + #11)] _____ 25. = 113.0 lb/ft³
26. Max dry density (From Curve No. M) _____ 26. = 112.0 lb/ft³
27. Compaction (#25 ÷ #26 x 100) _____ 27. = 100.9 %
28. Weight of Sample (#3) _____ 28. = _____ lb
29. Weight of stone removed from sample and retained on 3/4" or No. 4 sieve _____ 29. = _____ lb
30. Percent stone in sample (#29 ÷ #28 x 100) _____ 30. = _____ %
31. Weight of stone in one cubic foot of material (#24 x #30 ÷ 100) _____ 31. = _____ lb
32. Volume of stone in one cubic foot of material [#31 ÷ (Sp. Gr.* x 62.4)] _____ 32. = _____ ft³
33. Volume of wet soil in one cubic foot of material (1.00 less #32) _____ 33. = _____ ft³
34. Weight of wet soil in one cubic foot of material (#24 less #31) _____ 34. = _____ lb
35. Density of wet soil (#34 ÷ #33) _____ 35. = _____ lb/ft³
36. Density of dry soil [(#35 x 100) ÷ (#11 + 100)] _____ 36. = _____ lb/ft³
37. Compaction with stone removed (#36 ÷ #26 x 100) _____ 37. = _____ %
38. Moisture from zero air voids curve using (#25 or #36) _____ 38. = 18.0 %

(Water Added)
13.91
9.61
4.30
129.0
40
800

Procedure when sample contains less than 1/10 total weight in stone retained on 3/4" or No. 4 sieve***

Procedure when sample contains more than 1/10 total weight in stone retained on 3/4" or No. 4 sieve***

*Average Specific Gravity Values: Limestone = 2.6; Gravel = 2.5; Sandstone and Sandy Shale = 2.2

**Use this method only as a last resort.

***Use No. 4 sieve for penetration method only.

Does material tested meet specification requirements for: (write yes or no on each of following)

Max. dry weight YES; Moisture YES; Compaction YES

Does test check zero air voids curve (check which): Yes No

Action taken by (check which): Inspector or Project Engineer

If material tested does not meet specification requirements:

Additional rolling ordered Aerating ordered Watering ordered Other _____

Computed By R. J. Dutts

Checked By Mike Jordan

DOT-1224

Figure 3-1. C-88 Report on Compaction

Notes



INDEX

Chapter 4.0 Compaction of Soils

Section/Figure	Page	Old Section
4.1 Compaction	4-2	14
4.2 Moisture-Density Relationship	4-3	3.13
Penetration Resistance	4-3	3.13.4
Usefulness of the Test Results	4-4	3.13.5
Voids Ratio	4-4	3.14
4.3 Variations of the Moisture-Density Relationship	4-5	new
Changing the Compactive Effort	4-5	new
Temperature Effects on Soil	4-5	new
Coarse Aggregate Problem	4-6	new
Importance of Temperature and Coarse Aggregate Corrections	4-6	new
Ohio Typical Density Curves	4-6	
4.4 Test for Moisture-Density Relations and Penetration Resistance of Soils	4-7	21
Equipment	4-7	21.2
Procedure	4-7	21.3
4.5 Using the Ohio Typical Curves	4-9	21.4
Figure 4-1 Effects of Compaction on Soil	4-10	new
Figure 4-2 Temperature Effects on Soils	4-11	new
Figure 4-3 Coarse Aggregate Effects on Soils	4-12	new
Figure 4-4 Work Sheet for a Moisture-Density Curve	4-13	21-1
Figure 4-5M Moisture-Density and Penetration Resistance Curve	4-14	new
Figure 4-5 Moisture-Density and Penetration Resistance Curve	4-15	21-2
Figure 4-6 Loose and Compacted Lifts for the Proctor Test	4-16	new
Figure 4-7M Ohio Typical Density Curve	4-17	new
Figure 4-7 Ohio Typical Density Curve	4-18	new



4.0 Compaction of Soils

4.1 Compaction

Proper compaction at the proper moisture is the most effective and most economical way to improve the stability of soils. Satisfactory performance of pavement and embankment depends on the good compaction of the embankment and subgrade materials. Careful control is necessary to insure compliance with the specification compaction requirements for embankments and subgrades.

The density test is the principal means by which the Engineer determines whether or not the specified compaction requirements have been met. The number of tests to be made for a given quantity of embankment material placed purposely is not set by specifications or by administrative requirements. The Engineer may use his/her judgment to make tests at locations where the information is most needed for proper control.

For example, consider an area of embankment under construction where the soil and moisture conditions are uniform and ideal for good compaction and where previous compaction tests have shown that the specification requirements are being met consistently under the same roller coverages. As long as inspection shows that the uniform conditions of soil, moisture, lift thickness and roller coverages continue for this area, only occasional check tests for compaction are necessary.

Where relatively few tests are made because materials and conditions are uniform, document this by describing

conditions on the Compaction Forms or other appropriate project records. By avoiding a large number of tests in areas of uniform condition where specified compaction is being obtained consistently, allows the project personnel to concentrate their effort on other areas of the project, where conditions are less uniform or suspect.

Tests must be made especially in areas where inspection indicates that it is questionable if specified compaction is being obtained. Evidences of questionable compaction which can be determined by inspection include the following:

1. Low number of roller coverages.
2. Excessive deflection under heavy construction equipment.
3. Use of rollers of low efficiency.
4. Very wet soil.
5. Very dry soil.

The observation that a sheepsfoot roller will “walk out” or “ride high” on a layer of hard, dry soil is not in itself evidence of satisfactory compaction.

Where it is determined that compaction or moisture does not meet specification requirements, correction of the deficient area must be made before the next lift of embankment is placed over the deficient area. The Engineer must give specific instructions to inspectors covering their responsibility and authority as outlined in the specifications, to secure compliance with contract requirements.

4.2 Moisture-Density Relationship

In order to evaluate compaction testing the project personnel must first understand the moisture-density relationship and some of the problems associated with this relationship.

A relationship exists between the density of a soil as the moisture content of a soil is varied while the compactive effort remains constant. A standard force is used in the test that closely approximates the densities that can be readily obtained in field construction with sheepfoot rollers and other types of common compaction equipment. The greatest density obtained in the test is termed “maximum density” and the corresponding moisture content is termed “optimum moisture.”

The test used by the Department to determine the moisture-density relations of soil is AASHTO T 99 Method A. For details of this test procedure see Section 4.4.

The test consists of compacting soil passing a 19 mm (3/4 inch) sieve or 4.75 mm (No. 4) sieve in three equal layers in a 0.000943 cubic meter (1/30-cubic foot) cylinder mold, with each layer receiving 25 well distributed blows from a 2.5 kg (5.5 pound) rammer dropped 305 mm (12 inches). Use the 4.75 mm (No. 4) sieve when using penetration resistance to determine moisture content; otherwise use the 19 mm (3/4 inch) sieve. For each soil tested, this procedure is followed for several soil moisture contents compacted from damp to wet consistency. For each compacted specimen the dry weight and the moisture are determined. Each dry weight is plotted against its respective moisture content and a smooth curve is drawn through the points.

The maximum dry weight and optimum moisture can only be determined if two points are plotted on each side of optimum moisture on this curve. Maximum dry weight is the highest point of the curve resulting from this moisture-density test.

The optimum moisture is the water content at the highest point of the dry weight curve. This is the water content at which the maximum density is produced for a soil at a given compactive effort. This moisture

density relationship is shown in Figure 4-1A. A brief description follows of the influence of moisture on the compaction of soils.

At point 3, the soil is compacted at a moisture content where the compactive effort cannot overcome the friction or resistance of the soil to achieve a maximum density. As the water content increases, the particles develop larger and larger water films around them, which tend to “lubricate” the particles and make them easier to be moved about and reoriented into a denser configuration. However, as we continue to increase the moisture content, we eventually reach a water content where the density does not increase any further, which is point 1.

When compacted, the water starts to displace and replace soil particles because of the excess pore pressure on points from 1 to 2. The soil has just enough moisture to overcome most of the friction and not too much to have excess pore pressure to displace the soil at point 1. This moisture - density relationship is very good for soils passing the 4.75 mm (number 4) sieve as it relates to field compaction of soils. But there are problems when this relationship is extrapolated to soils larger than the number 4.75 mm (number 4 sieve).

Penetration Resistance

The pressure in mega pascals (MPa) pounds per square inch (lb/in²) required to force a needle of known end area into compacted soil at the rate of 12.7 mm/s (1/2 inch per second) for a distance of 76.2 mm (3 inches). A penetration resistance determination is made on each compacted specimen in the moisture-density test. Each penetration resistance reading is plotted against soil moisture at the time of the reading, and a smooth curve is drawn through the points. The relationship of penetration resistance to moisture and density is used in tests for soil compaction to help select a typical moisture-density which is representative of the soil being tested.

Usefulness of the Test Results

Results of the moisture-density test can be interpreted to give considerable general information on the load-carrying capacity and other properties of soils. More information useful in highway earthwork construction can be learned about the properties of a particular soil from this test than from any other one soil test.

The maximum density of a soil gives approximate information on its gradation. The optimum moisture gives approximate information on the clay and silt content of the soil. The shape of the moisture-density curve, which may vary from a sharply peaked parabolic curve to a flat one or to one sloping irregularly downward as the moisture content increases, gives additional valuable information showing the influence of moisture on the load-supporting value of the soil. For example, a flat moisture-density curve indicates a soil that will have about the same load-supporting power over a wide range in moisture contents.

The basic principle involved in the moisture-density relations of soils is the most important one in soil analysis for highway use. This basic principle is that for a given force of compaction and given moisture content, a soil will have a corresponding density. This can be stated in another way to emphasize the application of this principle to economy of rolling effort to secure specified compaction in highway earth embankments, as follows: For each soil, there is a particular moisture content at which a given compaction requirement can be secured with less compaction effort than at any other moisture content.

Structural properties of a soil vary with moisture content and density. For example, a clay soil at low density will have very high load-supporting power when dry, but when it is saturated at this same density it will have a very low load-supporting power. Hence, when the structural properties of a soil are being determined, its moisture content and density must be defined and controlled to permit accurate evaluation of the soil in that particular condition.

Moisture-density relations, such as optimum moisture and maximum density, are comparative factors. A high maximum density will range downward from 2000 to 2250 kg/m³ (125 to 140 pounds per cubic foot), dry weight. A low maximum density will range downward from about 1600 to 1350 kg/m³ (100 to 85 pounds per cubic foot), dry weight. A low optimum moisture coincides with a high maximum density and will be of the order of 7 percent. A high optimum moisture coincides with a low maximum density and may be of the order of 25 percent.

Void Ratio

The voids ratio is the ratio of the volume of voids to the volume of soil particles. The voids ratio of a soil will vary with its moisture content and degree of compaction or consolidation. Therefore, for a particular soil in different conditions, the voids ratio will vary and can be used to judge relative stability for load-carrying capacity, with these factors increasing as the voids ratio decreases.

4.3 Variations of the Moisture - Density Relationship

To truly understand the moisture and density relationship as it relates to soils compaction, the project personnel should understand what items effect this relationship. This section briefly addresses these issues.

This moisture-density relationship is effected by but not limited to the following conditions:

- A change in the compactive effort or a field compactive effort that is different from the laboratory testing compactive effort.
- A temperature of the compacted soil that is near or below freezing temperature.
- Coarse aggregate is added or subtracted from the soil.
- Significant amount of coarse aggregate in the soil.

Changing the Compactive Effort

The T-99 proctor test used to make the Department's moisture-density curves was originally made to simulate field compaction conditions. It uses a standard compactive effort that allows us to evaluate and compare the compaction testing of different soils. What happens to this moisture-density relationship as you increase or decrease this compactive effort?

See Figure 4-1B. The compactive effort may be increased or decreased to change the maximum density as much as 160 to 240 kg/m³ (10 to 15 lbs/c. ft.). As the compactive effort goes up, the curve shifts to the left and up along the same line of optimum. If the compactive effort is lowered the compaction curve shifts to the right and lower.

If the Contractor is using the compactive effort associated to the lower curve and the acceptance curve is the higher curve, then compaction cannot be achieved. If the case is reversed, then the Contractor should have no problem meeting the compaction requirements.

When the field roller compactive effort and laboratory test compactive effort are not compatible, because

their compactive effort is so different, compaction compliance may be a problem. Remember the original T-99 test was established many years ago and attempted to simulate the compaction effort of the compaction equipment of that era. It is the Contractor's responsibility to use the equipment necessary to achieve the specification density. The project personnel should keep this information in mind when evaluating field problems associated with compaction.

Temperature Effects on Soil

If a soil is compacted at significantly lower temperatures, the true maximum density cannot be achieved in the field. No soil is allowed to be compacted at frozen conditions. If you look at Figure 4-2 you can easily see why this is the case. The maximum density can change as much as 160 kg/m³ (10 lb./c. ft.) for soils compacted at a temperature difference of 20C (40F). But there may not be any difference in maximum density at all. Some soils are effected by temperatures and others are not. There is no formula that can take this temperature into consideration.

To check for this difference, the compaction procedure itself must be altered. When the Contractor is compacting the soil at temperatures lower than 7C (45F) or when the sight conditions warrant, the following procedure should be used:

1. Take the normal proctor test during the compaction testing. Choose the curve associated with this test.
2. Take enough soil to make another proctor. After the soil is warmed to a temperature approximately 21C (70C) make an additional proctor. Get another moisture and density for the warmed soil. Choose another curve with the results.
3. Compare the two results and use the higher curve if there is a difference. Use this procedure at any time the material is suspect in the field.

Coarse Aggregate Problem

Figure 4-3 shows a plot of adding or subtracting coarse aggregate to a soil mass and resulting change in the corresponding moisture-density curves.

As you add gravel or plus 4.75 mm (number 4) material to the soil, the optimum moisture shifts to the left and the maximum density increases. The average increase in density increases is about 1 percent per 10 percent of material retained on the 4.75 mm (number 4) sieve. This effect should be taken care of on lines 28 through 38 on the C-88 M (C-88).

If you sieve your material through the number 4 or 3/4 inch sieve and remove 20 percent coarse aggregate and do not take this into account, you could easily be one or two curves low.

Use the correction on the C-88M (C-88) compaction form where more than 10 percent material is retained on the 4.75 or 19mm (number 4 or 3/4) sieve. This correction lowers the in place density to match the proctor density. No correction is made to the moisture.

Importance of Temperature and Coarse Aggregate Corrections

The accuracy of all compaction testing is important. But the importance of making temperature and coarse aggregate corrections to the compaction test are less

obvious to the project personnel. Without these corrections the compaction testing could easily be off by more than 32 kg/m³ (2 pounds per cubic foot) without the project personnel being aware of a problem.

If the compaction testing is off by 32kg/m³ (2 pounds per cubic foot), or approximately one Ohio Typical (density) curve, this could result in a loss of 15 percent of the soil strength. If you are off by two curves, the potential loss could be 30 percent and so on.

The strength may not be apparent in construction, but in the long term it will have a huge effect on the performance of the embankment.

Ohio Typical Density Curves

The Ohio typical density curves are set of soil curves that were originally developed pre-1940's to represent all the soils in Ohio. They were developed using the standard proctor test in laboratory conditions. They started with an original set of 9 curves from Lab data that represented over 1,000 samples. Additional curves were added that represented over 10,000 lab samples. These curves are plotted in figure 4-7M (4-7).

A one point proctor is used to choose the curve that represents the soil under consideration. The procedure is similar to AASHTO T-272 Test. See Section 4.5.

4.4 Test for Moisture-Density Relations and Penetration Resistance of Soil

The purpose of this section is to outline procedures for determination of optimum moisture, maximum wet weight, maximum dry weight and penetration resistance of soils. This data is used to determine the suitability of soil for use in embankment and subgrade and to establish a standard for field compaction control.

The procedures outlined in this section follow AASHTO T-99, T-180, and T-272 with some minor modifications.

Equipment

1. Embankment compaction control kit with following components:
 - A. Cylindrical brass or cadmium plated steel mold approximately 102 mm (4 inches) in diameter, 114 mm (4 1/2 inches) in height and having a capacity of 0.000943m³ (1/30 cubic foot). The cylinder is mounted on a removable base plate and fitted with a detachable collar approximately 63 mm (2 1/2 inches) in height.
 - B. Brass or cadmium plated steel sleeve rammer having striking face 50 mm (2 inches) in diameter, weighting 2.5 kg (5 1/2 pounds) and equipped so as to control the height of drop to 305 mm (12 inches).
 - C. Steel straightedge 305 mm (12 inches) long.
 - D. Penetrometer.
 - E. Set of needles of known end area 32.3, 64.5, 129, 215 mm² (1/20, 1/10, 1/5 and 1/3 square inch sizes) for use with penetrometer.
 - F. Scale of 12 kg (25-pound) capacity sensitive to 1 gram (0.01 pound).
 - G. A 19 mm (3/4 inch) sieve and a 4.75 mm (No. 4) sieve.

- H. Circular slide rule of typical moisture-density curves for soil.
2. Oil or gas stove.
3. Portable oven unless dried by other methods.
4. Baking pans, approximately 300 x 200 x 63 mm (12 x 8 1/2 x 2 1/2 inches).
5. Masonry trowel and putty knife.

Procedure

Use a form similar to Figure 4-4 to record test data as obtained by the procedure outlined in this section. This suggested form shows an example of recorded test data. Figure 4-5M (4-5) shows curves plotted from the test data from Figure 4-4.

1. Secure a representative sample of soil 3-5 kg (6 to 11 pounds), depending on the size of sample required for method of moisture determination selected. See (6) below.
2. Pass the sample through a 4.75mm (No. 4) sieve when using penetration method and 19 mm (3/4 inch) sieve when using other drying methods.
3. Wet or dry the sample as required to bring the moisture content from 4 to 6 percent below optimum. Soil in this condition will be slightly damp and will readily form a cast when squeezed in the hand.
4. Take a proctor test. Form a specimen by compacting the prepared soil in the 102 mm (4-inch) diameter mold, volume 0.000943m³ (1/30 cubic foot), included in the compaction control kit, in the three equal layers to give a total compacted depth of about 127mm (5 inches). Compact each layer by applying 25 uniformly-well-distributed blows from the 2.5 kg (5-1/2 pound) rammer dropping from a height of 305 mm (12 inches) above the elevation of the soil. (See Figure 4-6 for recommended Loose and Compacted Lifts of Soil. Loose Lifts will change depending on the consistency of the soil.) Insure that the cylinder is resting on a uniformly

rigid foundation during compaction. A concrete block or piece of concrete beam is adequate for this purpose.

- A. Remove the extension collar and carefully trim the compacted soil even with the top of the mold by means of the straightedge. Add fine material to fill the voids if required.
 - B. Weigh the cylinder and sample.
 - C. Calculate the density of the specimen by subtracting the weight of mold from the weight of the specimen and mold, and multiply the difference by 1060 metric (30 English). This is the wet density of the proctor soil.
5. Determine the resistance of the soil to penetration by use of the soil penetrometer, contained in the compaction kit, with attached needle of known end area, using the following procedure:
- A. Place the mold containing the soil on a smooth space between your feet.
 - B. Hold the penetrometer in a vertical position over the sample.
 - C. Force the needle into the sample at the rate of 13mm/sec (0.5 inch per second) for a distance of not less than 75 mm (3 inches). Use a needle size that will give readings between 90N and 330N (20 and 75 pounds), except for the 32.3 mm² (1/20 square inch) needle, do not use readings above 270 N (60 pounds).
 - D. Repeat this process at least two more times. Insure the penetrations are away from the edge of the mold, and spaced not to interfere with one another.
 - E. Divide the average penetrometer reading by the end area of the penetration needle and record the resulting value as the penetration resistance of the soil, expressed in mega-pascals (pounds per square inch). It may not be possible to make the

penetration resistance test in the first one or two compacted specimens due to the low moisture content of the sample. **Warning: Use nuclear method or drying method to determine percent moisture in lieu of the penetration resistance method when performing a one (1) point proctor test. Only use the penetration resistance method as a last resort. This method is being misused.**

6. Remove the material from the mold and slice vertically through the center. Take a representative sample of the material from one of the cut faces and determine the moisture content by the appropriate method outlined in Chapter 3. If the only available scales are those included with the compaction control kit, a half kilogram (one-pound) sample will be required for the moisture determination. However, if a more sensitive gram scale, such as that included with the cylinder density kit, is available, a 100-gram sample should be used for the moisture determination. A smaller sample will dry faster and the soil sample required for the complete test is not so large.
7. Thoroughly break up the remainder of the material until inspection shows that it will pass a 4.75 mm (No. 4) sieve. It is not necessary to pass the material through the sieve. Add water in sufficient amount to increase the moisture content of the soil sample by 2 or 3 percent, and repeat the procedure outlined in (4) through (6).
8. Repeat 4-7, each time adding water until at least 4 readings for wet weight, dry weight and moisture content are obtained. This process is continued until a minimum of two points are plotted on the wet and dry side of the dry weight curve and there is a decrease in the wet weight.
9. Use Figure 4-4 as an example and plot test data as follows:
 - A. Plot wet weight versus moisture content of

- the successive tests on linear graph paper. Draw a smooth curve between the successive points. The peak of this curve is the maximum wet weight of the material being tested, for this standard method of compaction. This maximum weight is not used for compaction acceptance.
- B. Plot dry weight versus moisture content of the successive tests on linear graph paper. Draw a smooth curve between the successive points. The peak of this curve is the maximum dry weight of the soil. The moisture content at this point is the optimum moisture. This curve is used for compaction acceptance.
- C. Plot penetration resistance versus moisture content of the successive samples on linear graph paper. Draw a smooth curve between these points. This is the penetration-resistance curve.

4.5 Using the Ohio Typical Curves

Optimum moisture and maximum dry weight can be determined by the use of the one-point moisture-density test and typical moisture-density curves as described

in Section 4.3 and T-272. Once the wet weight and percent moisture is obtained from the proctor test, it can be used to find the curve that represents the soil being tested. (See Figure 4-7M (4-7).)

Use the curve that is chosen at the intersection of the wet weight and the moisture content of the proctor test. If the intersection is between two curves, choose the next higher curve. (See Section 6.2 “Selecting a Typical Curve Using the Nuclear Gauge Results”) Regardless of the Compaction Testing method used, always perform a one point proctor when using the Ohio Typical Density Curves. **Warning: Use nuclear method or drying method to determine percent moisture in lieu of the penetration resistance method when performing a one (1) point proctor test. Only use the penetration resistance method as a last resort. This method is being misused.**

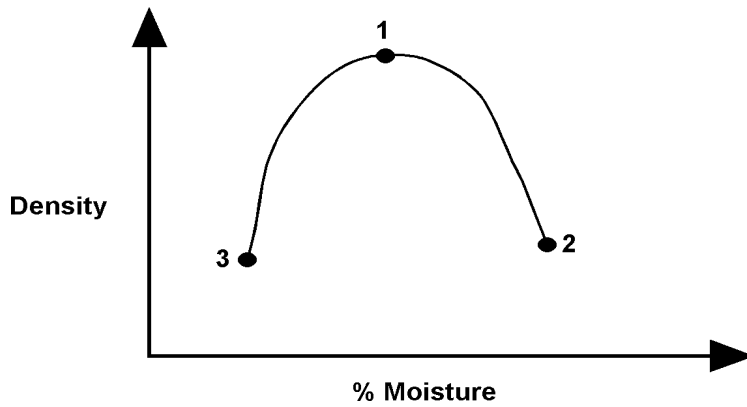

Figure 4-1A. Typical Moisture Density Curve

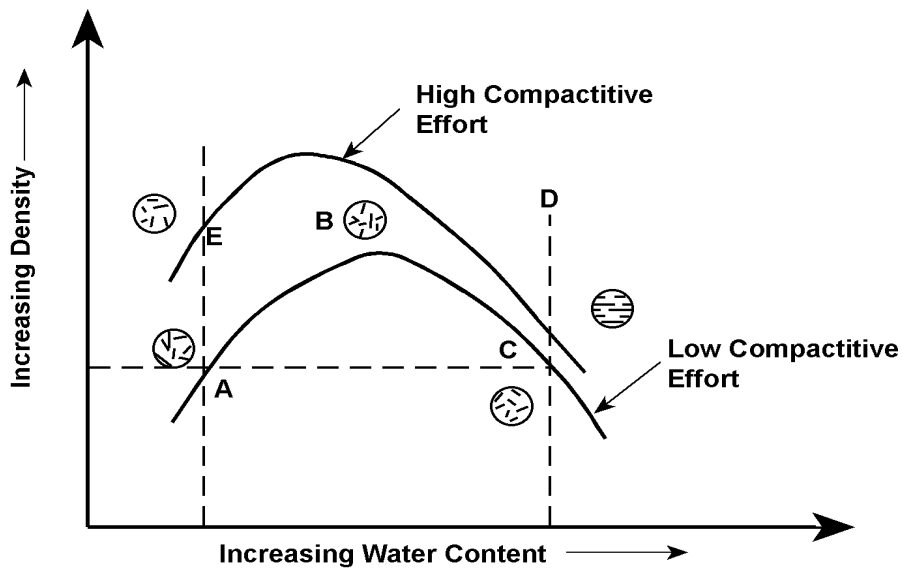

Figure 4-1B. Changing Compactive Effort

Figure 4-1. Effects of Compaction on Soil

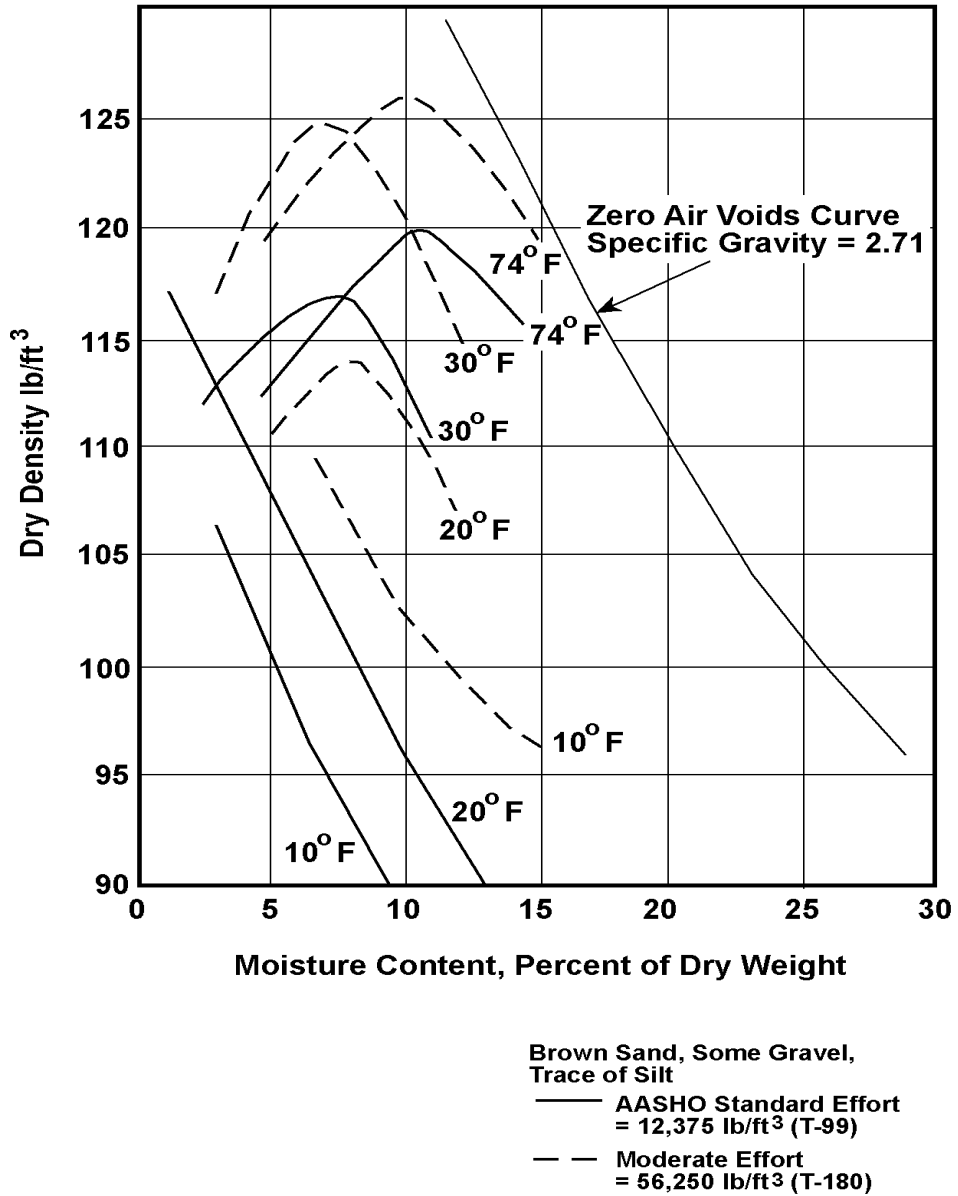

Figure 4-2. Temperature Effects on Soil*
(TRB Guide to Earthwork Construction)

*Use as example only. Not to be used as correction in compaction testing.

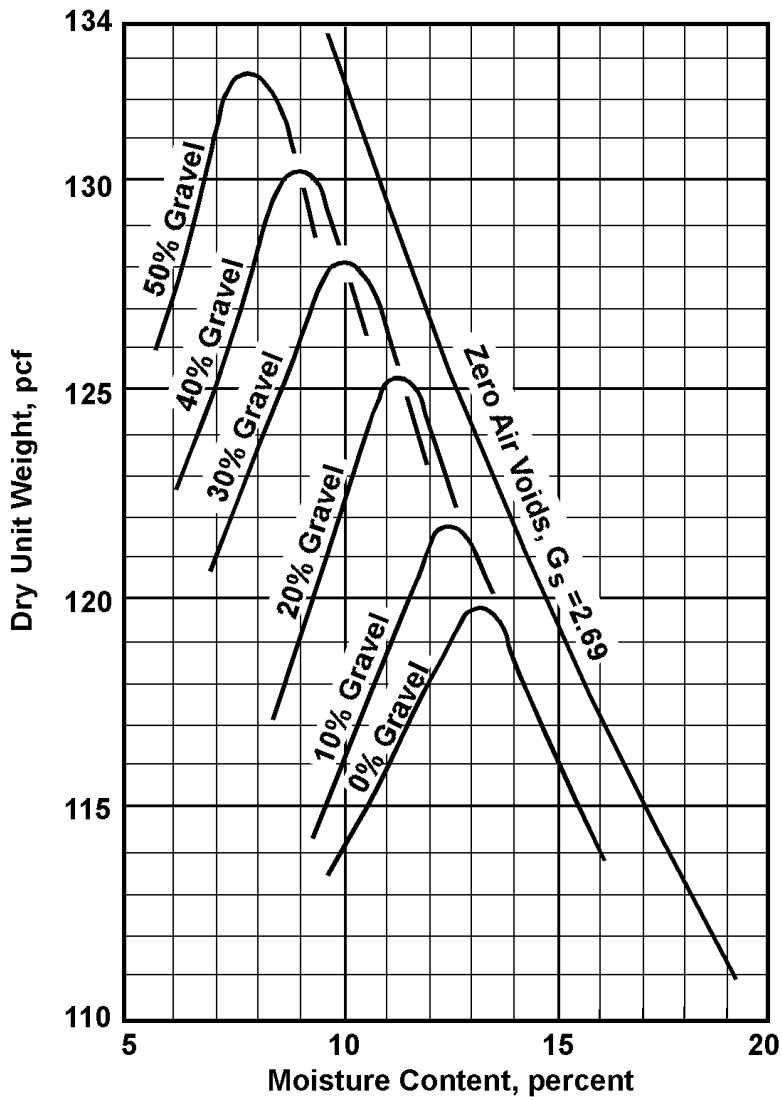

Figure 4-3. Coarse Aggregate Effects on Soils*
(HRB Bulletin 319)

*This is an example only and not to be used as a correction in compaction testing.

C-166
1/96

STATE OF OHIO
DEPARTMENT OF TRANSPORTATION
WORK SHEET FOR
MOISTURE-DENSITY TEST

Project No. 722 (68)
County Ashtand
Sample 1

Date 10-10-68
Operator T. Williams

Tare _____

Wt. of Compacted Sample + Container Kg (lbs.)	Wt. of Sample Kg (lbs.)	Wt. of Sample Kg/m ³ (lbs. per cu. ft.)	Penetration and Resistance		Moisture Determination						Dry Wt. of Soil Kg/m ³ (lbs. per cu. ft.)		
			Size, mm ² (sq. in.)	Reading N (lbs.)	Pressure mPa (lbs. per sq. in.)	Dish No.	Wet Wt. + Dish Gr.	Dry Wt. + Dish Gr.	Water Wt. Gr.	Dish Wt. Gr.		Soil Wt. Gr.	% Water (Dry)
6.051 (13.34)	1.601 (3.53)	1698 (105.9)				1	962	964	28	400	584	52	1614 (100.5)
6.183 (13.63)	1.733 (3.83)	1837 (114.6)				2	986	987	49	380	557	88	1638 (105.2)
6.231 (13.87)	1.842 (4.06)	1953 (121.8)				3	971	909	62	390	519	11.9	1745 (108.8)
6.409 (14.13)	1.960 (4.32)	2076 (129.6)	32.3 (1/20)	267 (60)	827 (1200)	4	996	917	79	410	507	15.6	1798 (112.1)
6.423 (14.16)	1.973 (4.35)	2092 (130.5)	64.5 (1/10)	178 (40)	276 (400)	5	948	862	86	400	462	18.6	1764 (110.1)
6.369 (14.04)	1.919 (4.23)	2056 (126.9)	21.5 (1/5)	222 (50)	102 (150)	6	952	845	107	380	465	23.0	1654 (105.2)

Max. Dry Wgt. 1802 (112.5) Kg/m³ (lbs./cu. ft.)
Opt. Moisture 15.5 %

Remarks _____

Curve Project Curve
DOT-1636

Figure 4-4. Work Sheet for a Moisture-Density Curve

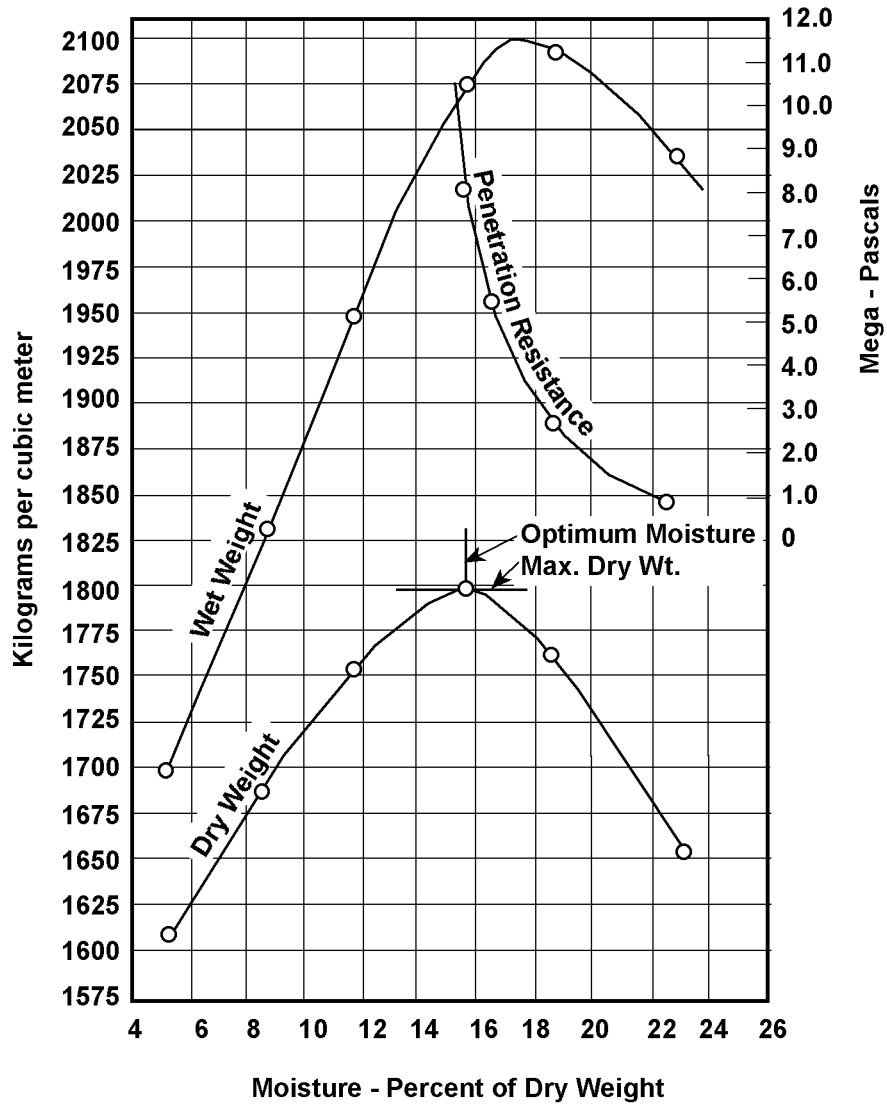

Figure 4-5M. Moisture-Density and Penetration Resistance Curve

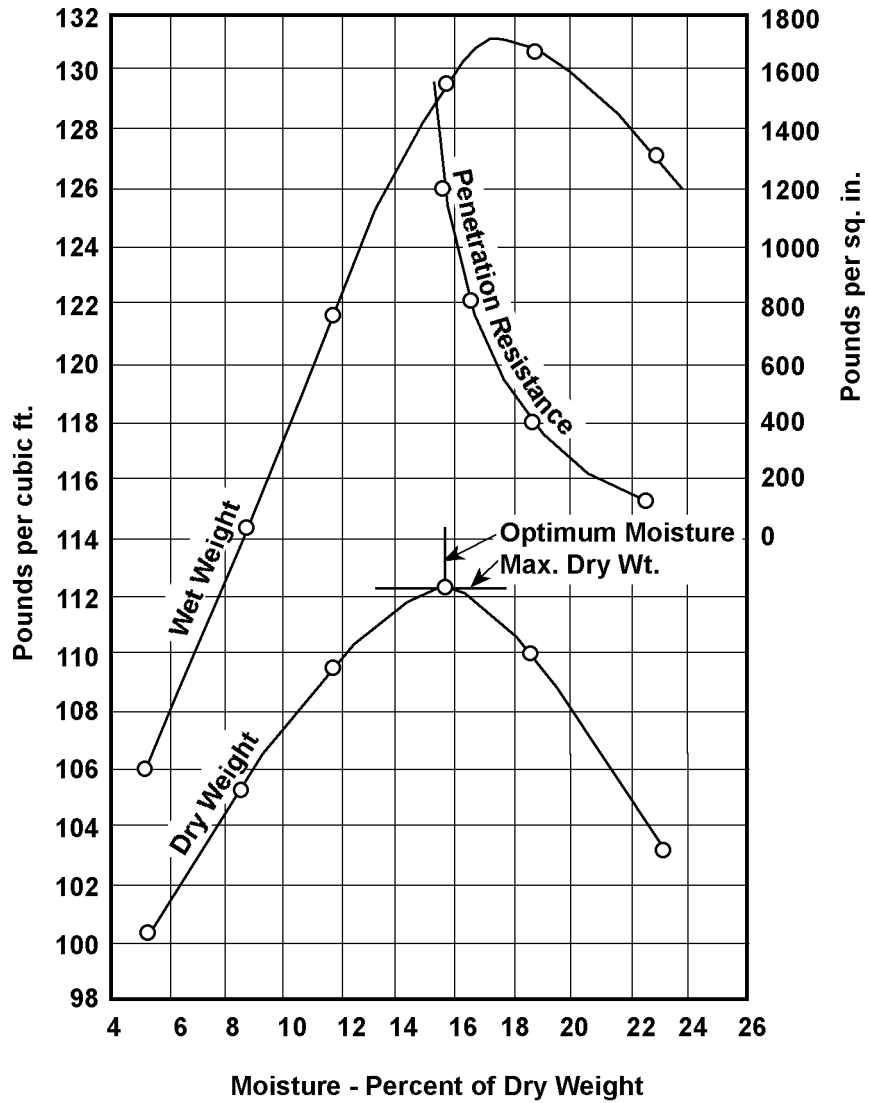
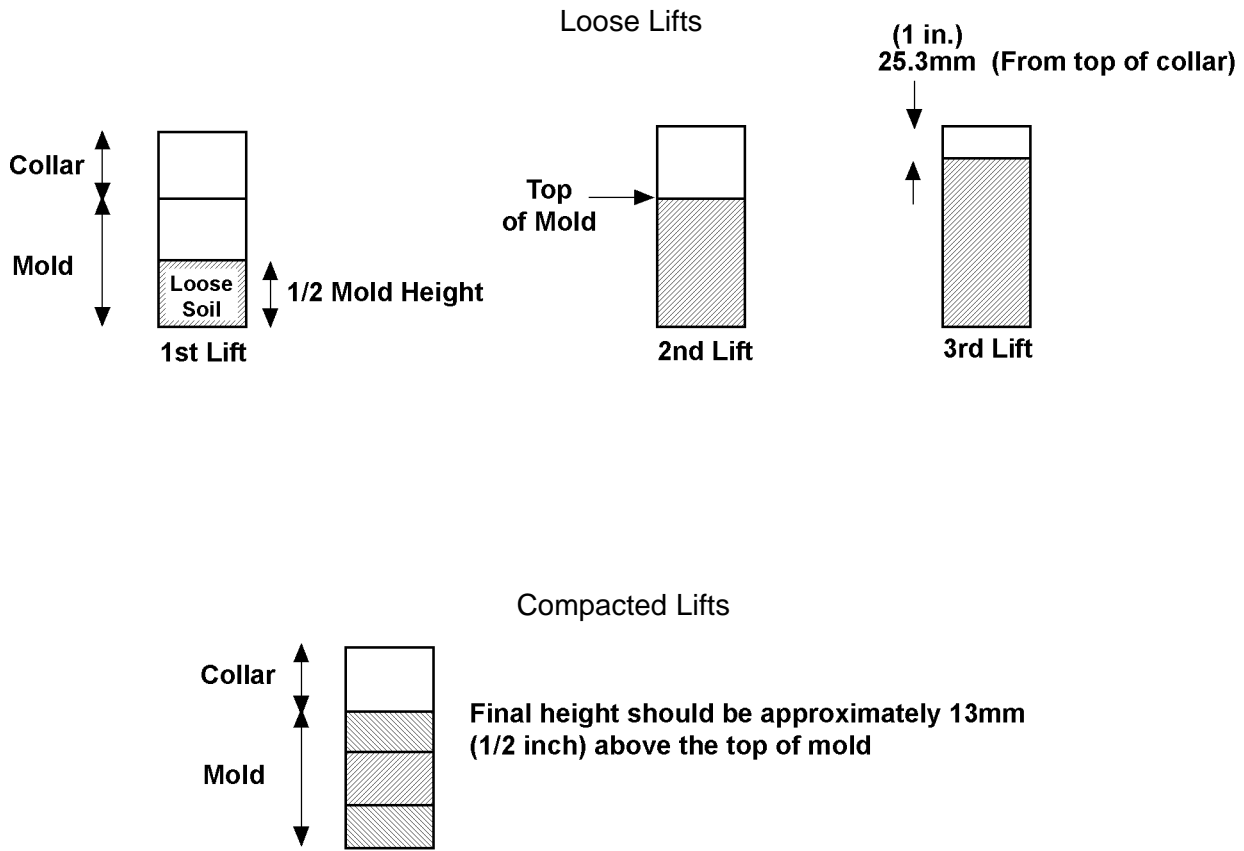
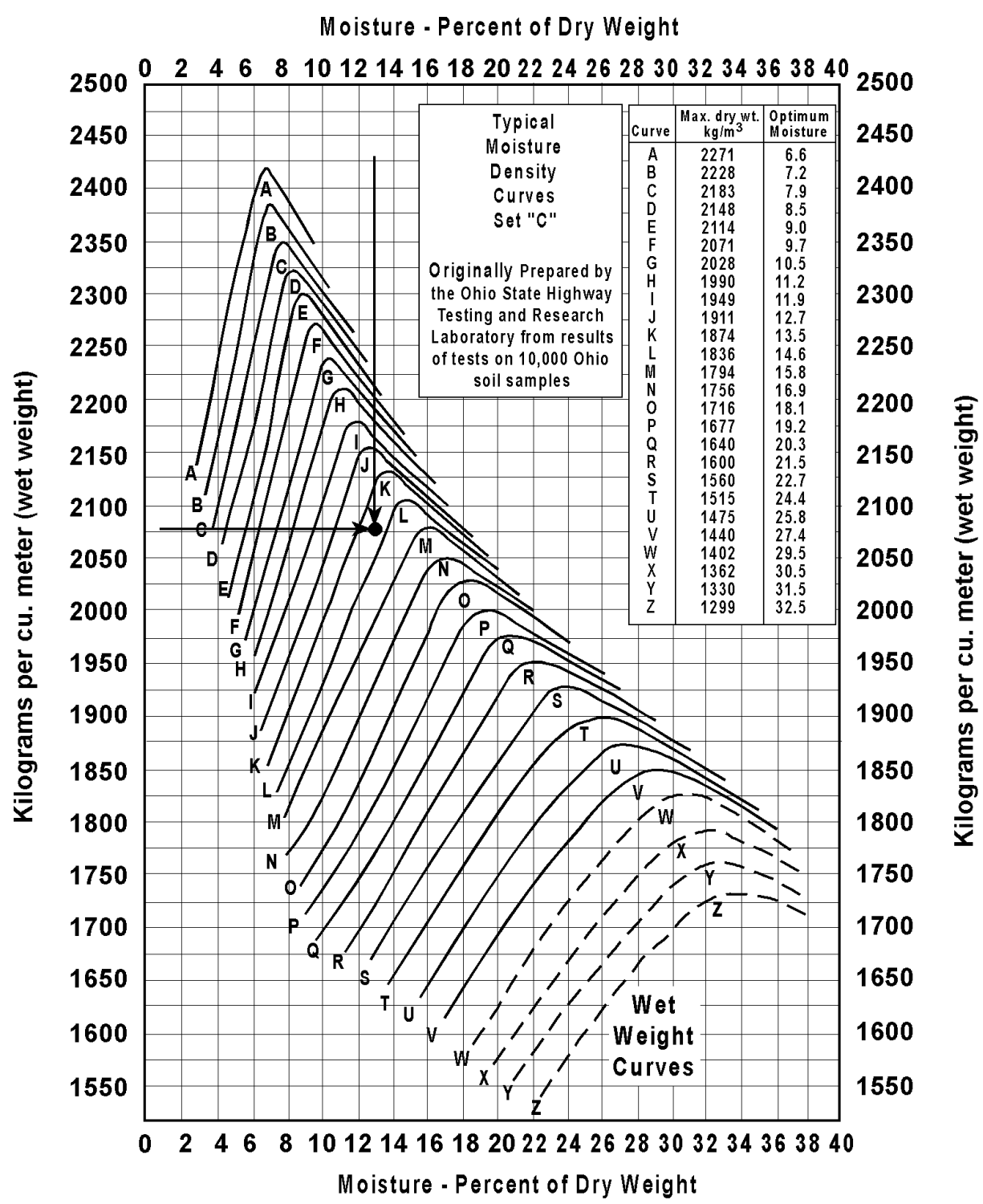

Figure 4-5. Moisture-Density and Penetration Resistance Curve



- 3 Equal Lifts
- 25 Drops Each Lift
- 304 mm (12 in.) Height with 2.5 kg (5.5 lb) Hammer

Figure 4-6. Loose and Compacted Lifts for the Proctor Test



* Computer re-drawn February 1996

Figure 4-7M. Ohio Typical Density Curve

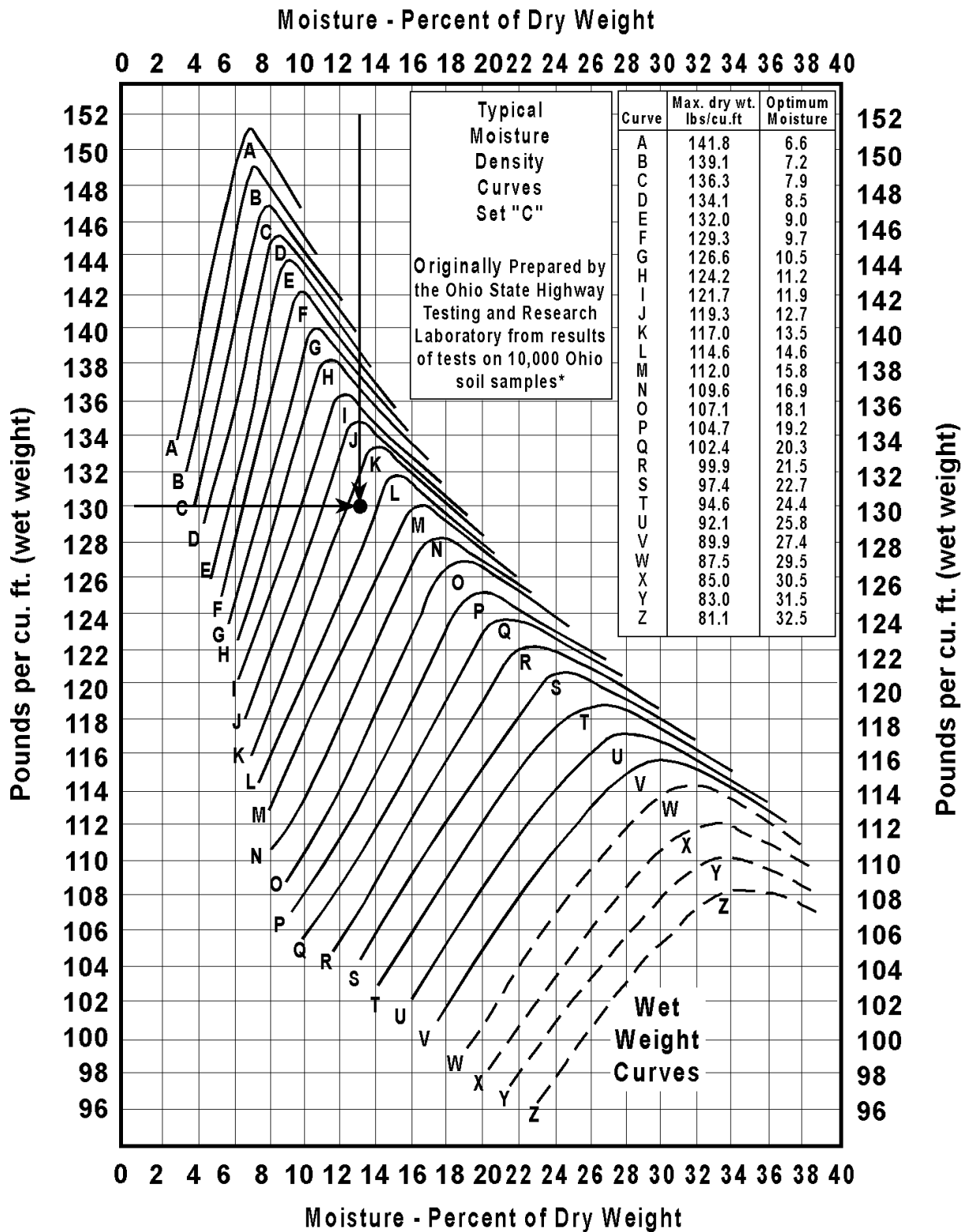

* Computer re-drawn February 1996

Figure 4-7. Ohio Typical Density Curve

Notes



INDEX

Chapter 5.0 Compaction Testing of Soils

Section/Figure	Page	Old Section
5.1 Equipment	5-2	23.2
5.2 Preparation of the Test Site	5-2	23.3



5.0 Compaction Testing of Soil

Control of compaction includes making moisture and density determinations for the purpose of establishing whether the compaction meets the requirements prescribed in 203. A sufficient number of tests are to be made to insure the construction complies with the specifications. It is recommended that the nuclear gauge be used for compaction testing. The sand-cone, rubber-ballon, and cylinder density test may also be used. The sand-cone is preferred over the cylinder density and rubber-ballon. The rubber ballon is not covered in this manual. Follow the manufacturer's recommendations for this method. Regardless of the method chosen, a one point proctor is used to identify the curve that represents the soil in question for each compaction test.

5.1 Equipment

1. Embankment compaction control kit. (See Section 4.4. for components.)
2. A 75 mm (3-inch) or 100 mm (4-inch) post-hole auger.
3. A container with a 114 mm (4-1/2 inch) hold cut in the bottom.

4. A sand cone apparatus as shown in Figure 7-6, Troxler 3440 Nuclear Gauge in Figure 6-5, or cylinder density apparatus, Figure 8-1.
5. 12 to 23 kg (25 to 50 pounds) of dry uniform natural sand passing the 2.00 mm (No. 10) sieve.
6. Form C-88M (C-88), Report on Compaction, Figure 7-1M (7-1), Form C-135B-M (C-135B), Figure 6-6M (6-6), or C-89M (C-89), Figure 8-2M (8-2).

5.2 Preparation of Test Site

Select a location for the density test which is representative of a rolled area of the embankment layer being constructed. If loose, uncompacted material, such as results from sheepsfoot rolling, exists on the surface, remove the loose material, exposing the compacted material underneath. Carefully level the test area by any convenient means, such as a dozer, grader, hand shovel, straightedge, etc.

Notes



INDEX

Chapter 6.0 Compaction Testing of Soil Using A Nuclear Gauge

Section/Figure	Page	Old Section
6.1 Density Test	6-3	23.4.3.1
6.2 Selecting a Typical Curve Using the Nuclear Gauge Results	6-5	23.6.3
Figure 6-1 Nuclear Gauge Direct and Backscatter Position	6-6	new
Figure 6-2 Nuclear Gauge at the Standard Count Position	6-7	new
Figure 6-3 3440 Key Pad Layout	6-8	new
Figure 6-4 Scaper Plate Tools and Use	6-9	new
Figure 6-5 Positions of the Nuclear Gauge	6-10	new
Figure 6-6M Example of C-135B-M Nuclear Gauge Compaction Form	6-11	new
Figure 6-6 Example of C-135B Nuclear Gauge Compaction Form	6-12	new



6.0 Compaction Testing of Soil Using a Nuclear Gauge

For nuclear measurement of the density of soils, gamma rays emitted into the soils from a gamma source are scattered by the electrons in the soil and lose energy in the process. The number of scattered rays returned and counted on a scaler depends on the average length of the path of the ray between the detector and source. (See Figure 6-1.) The electron density increases proportionally with the density of the soil and causes greater scattering and energy loss. Therefore, the chances that scattered gamma rays returning to the detector with sufficient energy to be counted become smaller and the count rate drops with increased soil density. In common types

of soils, a low gamma ray count indicates a high density, and a high count indicates a low density.

Density determinations can be made with the source in any one of the following two positions relative to the soil:

1. Backscatter. Source and detector in the meter are resting on surface of the material being tested.
2. Direct Transmission. Source in rod are extended below the meter into the material being tested, and the detector in the meter are on the surface of the material.

6.1 Density Test

Use form C-135B-M (C-135B) for density testing when using a nuclear gauge. See Figures 6-6M and 6-6. The following is a summary of the gauge operations when testing soils. Consult the owners manual of procedures or AASHTO-T-238 and AASHTO-T-272 for further explanation. The gauge is self-driven throughout the process. The operator pushes a button and the gauge asks a question or gives an answer. The operation is straightforward.

1. Determine the standard count. This should be done for every day of operation.

A. Put the gauge on standard block with the handle opposite the metal plate. See figure 6-2. Make sure the standard block is resting on material with weights of 1600 kg/m³ (100 lbs. per c. ft.).

B. Press “on” on the control panel (see Figure 6-3) and wait about 4 minutes to warm up. Gauge may already be on prior to placing it on the block. The gauge will beep when warm up is complete and will give you the following information

Depth: Safe Position

Time: 1 min. (may be a longer duration)

Battery: Volts

C. Press standard button:

Read out Do you want to take a new standard?

If correct..... Press Yes

Is the gauge in the safe position?

If correct..... Press Yes

Readout:.....Taking a standard count.

It takes 240 seconds. Gauge will beep when complete.

D. Readout when the standard count is complete:

MS xxxx 0.8%P

DS xxxx 0.4%P

- Do you want to accept the new standard?
P-Pass, F-fail
- If reading is within 1% for density or 2% for moisture the standard passed.
- Record standard count on lines 4 and 7 on C-135B-M (C-135B).
- Press “Yes” if acceptable.

Readout	Ready
	Depth
	Volts

E. Ready to take the readings

2. Taking nuclear gauge readings:

A. Clear away all loose material or dried crust and obtain a level area of sufficient size to accommodate the gauge. Use the scraper plate to help the smooth out the surface. Use the native fines or fine sand to fill the voids to finish smoothing out the surface. The maximum void beneath the gauge shall not exceed 3 mm (1/8 in).

B. Make a hole perpendicular to the prepared surface by using the pin provided by the manufacturer. Mark the outside of the scraper plate. See Figure 6-4.

C. Remove the scraper plate and position the nuclear gauge on the prepared location

D. Extend the rod to the required depth. See Figure 6-5.

Backscatter position	Subbase
16 mm (six-inch) depth	Embankment
31 mm (twelve-inch) depth	Subgrade

The gauge will tell you the depth at which you are.

E. Pull gauge toward the detector end or away from handle to seat the gauge into position. (See Figure 6-1.)



F. Press Start/Enter.

G. After one minute

Read out DD - Dry Density

WD - Wet Density

o/o M - Percent Moisture

H. Record information on the C-135B-M (C-135B) on Lines 5, 6, and 8.

I. Check the nuclear gauge readings by performing the calculation on Line 9 of form C-135B-M (C-135B).

6.2 Selecting a Typical Curve Using the Nuclear Gauge Results

1. Secure a representative soil sample of about 5 kg (10 pounds). Use the soil between the end of the probe and the back of the gauge. Use the soil measured by the nuclear gauge. (See the figure 6-1.)
2. Sieve the material through a 19.0 mm (3/4 inch) sieve. If more than 10% of the soil or 1/2 kg (one pound) in 5 kg (10 pound) sample, make a correction by using Lines 28 through 38 on Form C-88M (C-88). See Section 7.5.
3. Thoroughly mix the material passing the 19.0 mm (3/4 inch) sieve.
4. Take a proctor test as described in Section 4.4 in the Procedure Section Step 4. **Warning: Take a proctor test for every compaction test. A soil cannot be correctly identified without this test.**
5. Record the results on Lines 10 through 13 on the C-135B-M (C-135B).
6. Pick the curve from proctor wet density and moisture from gauge readings or another drying method. Use the printed Ohio Typical Density Curve or the Project Curves. (Reference AASHTO T-272.)
 - A. Draw a horizontal line through the wet density per cubic meter (cubic foot) on the typical or project curves of the proctor weight on Line 13 on the C-135B-M (C-135B). Extend a vertical line from the percent moisture shown on Line 8 on the C-135B-M (C-135B), to intersect the horizontal line. If the intersection falls on a curve, choose the curve. If the intersection falls between two curves, choose the next highest curve.
7. Pick a curve using the slide rule. Pull out the slide of the slide rule and set the short tangent line on the wet weight scale at the wet weight recorded on Line 12 of Form C-135B-M (C-135B). Rotate the chart until the short tangent line intersects a wet weight curve near the peak. Eliminate from consideration all curves that lie completely below this line. Note that the short tangent line intersects the wet weight curve at two points, one on the wet (right) side of the peak, and one on the dry (left) side. Again rotate the chart until the cross formed by the short tangent line of the slide and the center radial line of the window lies on the wet weight curve with the center radial line as near as possible to the percent moisture from Line 8 of Form C-135B-M (C-135B), use the indicated curve. After the curve is selected, record optimum moisture on Line 14 and the maximum dry weight on Line 15 of Form C-135B-M (C-135B).
8. Checking Compaction
 - A. Find the maximum dry weight corresponding to the curve found above.
 - B. Place the maximum density and optimum moisture on Lines 14 and 15 on Form C-135B-M (C-135B).
 - C. Calculate the percent compaction on Line 17 and compare to the allowable in the specifications. If density and stability are achieved, then moisture passed. See Section 3.1.
9. Check zero air voids using Section 7.8.

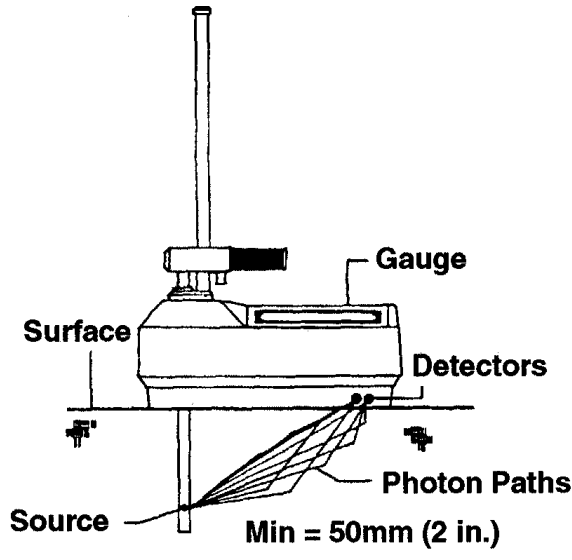

Direct Transmission

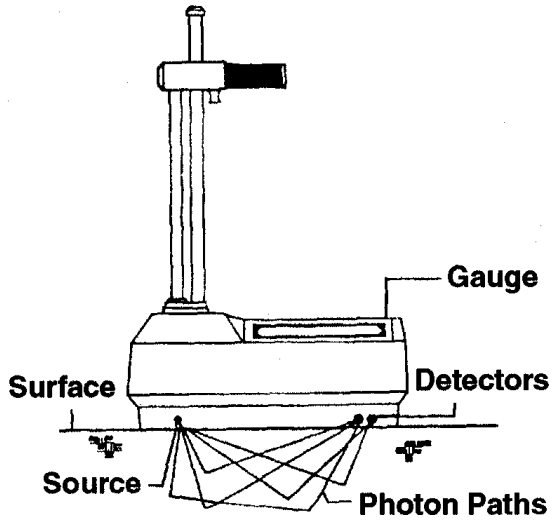

Backscatter

Figure 6.1 Nuclear Gauge Direct and Backscatter Position
(From Troxler)

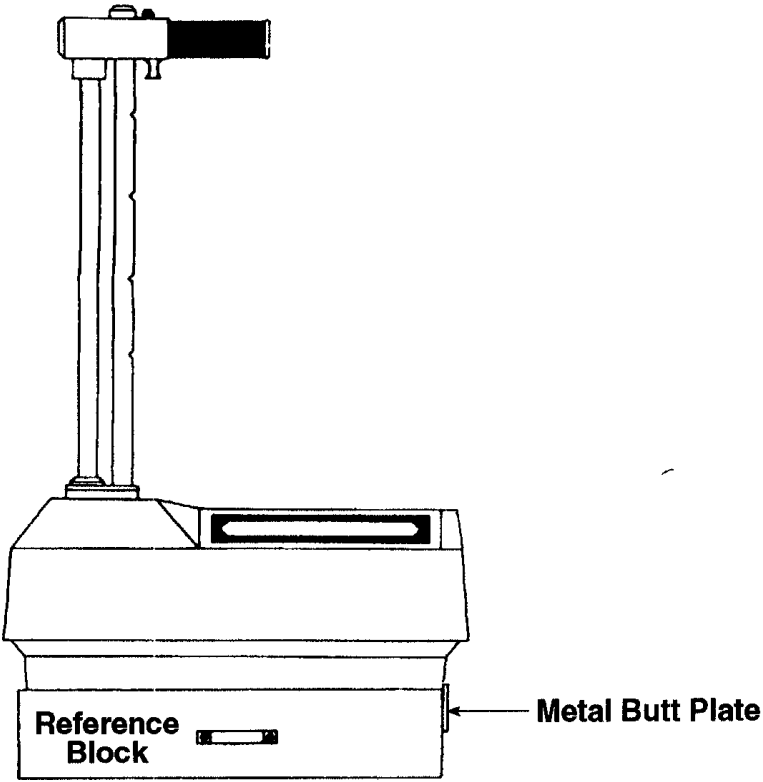

**Figure 6.2 Nuclear Gauge at the Standard Count Position
(From Troxler)**

YES <small>EXIT</small>	YES/CE <small>C/CE</small>	STATUS	MODE	SPECIAL
		7	8	9
STORE <small>MS</small>	OFFSET <small>MR</small>	PROJECT	PRINT	ERASE
		4	5	6
PROCTOR/ MARSHALL <small>+</small>	TIME <small>-</small>	COUNTS	DEPTH	CALC.
		1	2	3
SHIFT <small>x</small>	STANDARD <small>÷</small>	RECALL	.	START/ ENTER <small>=</small>
		0		

**Figure 6-3. 3440 Keypad Layout
(Troxler Manual of Procedure)**

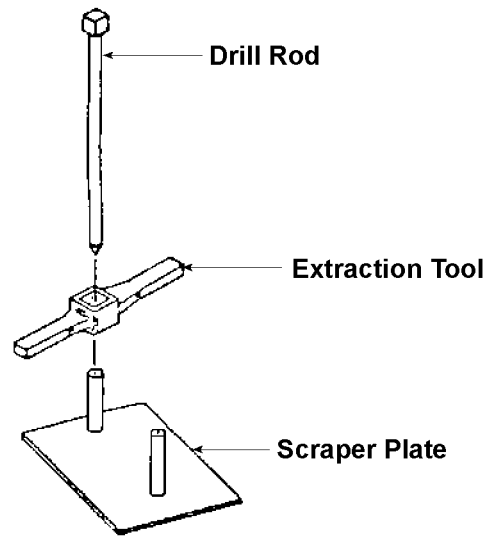

Tools

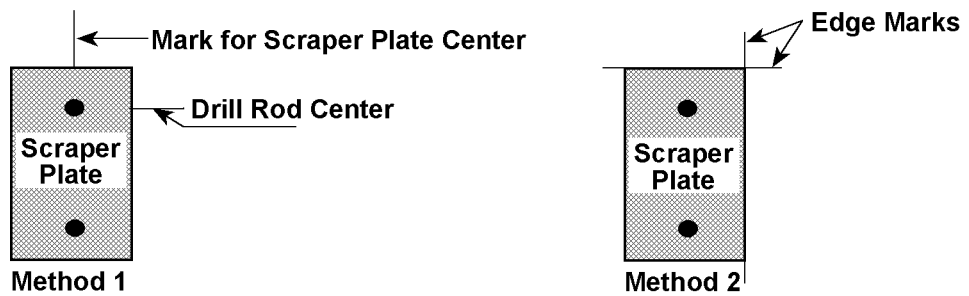

Figure 6-4. Scraper Plate Tools and Use

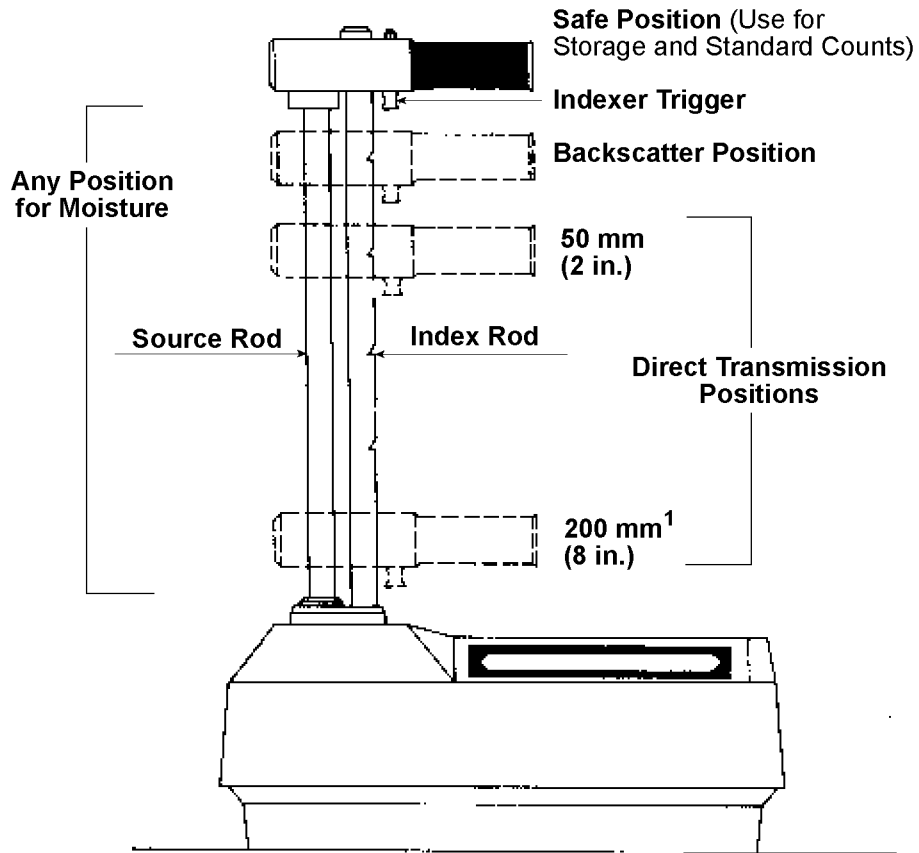

Figure 6-5. Positions of the Nuclear Gauge



STATE OF OHIO
DEPARTMENT OF TRANSPORTATION

C-135B-M

1/96

NUCLEAR GAUGE COMPACTION FORM

Sample ID: 66666666-02 Personnel ID: 111-0000-111 Date Sampled: 8/22/92
 Type of Inspection: COMPACTION Producer Code: 55555-2 Contractor: F.T. DEFIANCE
 Material Code: 20340001 Test Results: PASS

Project/P.O. 935(90) P.O. Ind. 2034-0001 Ref. Number 45 Item Code _____ Ref. Number _____
 Item Code _____

Test of (check which): Embankment Subgrade Base Other
 Test of (check which): Limestone Gravel Slag Sandstone Granulated Slag Other
 From Sta 1 + 000 at 5 meters (ft or ft.) of centerline to Sta 2 + 000 at 10 meters (ft or ft.) of centerline, at approx. Elevation 295.7 m
 See Report No. _____ (check which): Wet Dry Maximum Density from Test Section _____ kg/m³ Optimum Moisture _____ %
 98% of Max. Density _____ kg/m³ Check Method used: Direct Transmission Backscatter Probe Depth 152.4 mm

1. Station of test	1. <u>3+337.6</u>	2. <u>3+337.6</u>	3. _____	4. _____	5. _____	6. _____
2. Distance(right) or left of centerline if different than above _____ (m)	2. <u>10</u>	3. _____	4. _____	5. _____	6. _____	7. _____
3. Approximate Elevation if different than above _____ (m)	4. <u>2208</u>	5. <u>2307</u>	6. <u>2130</u>	7. _____	8. <u>8.3</u>	9. <u>8.3</u>
Procedure for Determining Dry and Wet Density						
4. Standard Count for Density	_____	_____	_____	_____	_____	_____
5. Wet Density of soil from gauge _____ (kg/m ³)	_____	_____	_____	_____	_____	_____
6. Dry Density of soil from gauge _____ (kg/m ³)	_____	_____	_____	_____	_____	_____
Procedure for Determining Moisture Content						
7. Standard Count for moisture	_____	_____	_____	_____	_____	_____
8. Moisture content of soil from gauge * _____ (%)	_____	_____	_____	_____	_____	_____
9. Check for moisture content [(#5 ÷ #6 x 100) - 100] _____ (%)	_____	_____	_____	_____	_____	_____
Take sample (about 4.5 kg) of material from area tested for density. Procedure when sample contains less than 1/10 total weight in stone retained on 19.0 mm or 4.75 mm sieve**						
10. Weight of 0.000943 m ³ compacted wet soil + weight of container (kg)	<u>6.328</u>	<u>6.355</u>	_____	_____	_____	_____
11. Weight of 0.000943 m ³ container _____ (kg)	<u>4.191</u>	<u>4.191</u>	_____	_____	_____	_____
12. Weight of 0.000943 m ³ compacted wet soil (#10 - #11) _____ (kg)	<u>2.137</u>	<u>2.164</u>	_____	_____	_____	_____
13. Density of compacted wet soil (1060 x #12) _____ (kg/m ³)	<u>2265</u>	<u>2294</u>	_____	_____	_____	_____
14. Optimum moisture from dry density curve (Curve No. <u>D</u>) - _____ (%)	<u>8.5</u>	<u>8.5</u>	_____	_____	_____	_____
15. Maximum Dry Density (Curve No. <u>D</u>) using line 6 _____ (kg/m ³)	<u>2148</u>	<u>2148</u>	_____	_____	_____	_____
16. Amount above _____ or below <input checked="" type="checkbox"/> optimum moisture (#14 - #8) _____ (%)	<u>1.0</u>	<u>0.2</u>	_____	_____	_____	_____
17. Compaction [(#6 ÷ #15) x 100] _____ (%)	<u>97.0</u>	<u>99.2</u>	_____	_____	_____	_____
17a. Moisture from zero air voids curve usig Line 6 _____ (%)	<u>10.5</u>	<u>9.5</u>	_____	_____	_____	_____
18. Does material tested meet Specification requirements? Yes <input type="checkbox"/> No <input type="checkbox"/>	<u>NO</u>	<u>YES</u>	_____	_____	_____	_____
19. "A" Rolling ordered; "B" Aerating ordered; "C" Watering ordered	<u>A</u>	_____	_____	_____	_____	_____
20. Date Tested	<u>8/22/92</u>	<u>8/22/92</u>	_____	_____	_____	_____

* In percent of Dry Density.
 ** Refer to C-88-M, lines 28 - 38 when soil sample contains more than 1/10 total weight in stone retained on 19.0 mm or 4.75 mm sieve; Use No. 4 sieve for penetration method only.

Computed By CHARLIE COMPACTION Checked By FRED DIRECTOR
 DOT-1639

Figure 6-6M. Example of C-135 B-M Nuclear Gauge Compaction Form

STATE OF OHIO
DEPARTMENT OF TRANSPORTATION
NUCLEAR GAUGE COMPACTION FORM

C-135B

1/96

Sample ID: 66666666-02 Personnel ID: 111-0000-111 Date Sampled: 8/22/92
 Type of Inspection: COMPACTION Producer Code: 55555-2 Contractor: FT. DEFIANCE
 Material Code: 20340001 Test Results: PASS

Project/P.O. 935-90 P.O. Inc. 203 Item Code 203 Ref. Number 25 Item Code Ref. Number

Test of (check which): Embankment Subgrade Base Other
 From Sta 1 + 00 at 5 feet Limestone Gravel Slag Sandstone Granulated Slag Other
 See Report No. (check which): Wet Dry Maximum Density from Test Section lb/ft³ Optimum Moisture %
 98% of Max. Density lb/ft³ Check Method used: Direct Transmission Backscatter Probe Depth 6 inches Min. Compaction Req.: 98 %

1. Station of test	1. <u>109+50</u>	2. <u>109+50</u>	3. <u> </u>	4. <u> </u>	5. <u> </u>	6. <u> </u>
2. Distance (right or left of centerline if different than above) (ft)	2. <u>10</u>	3. <u>12</u>	4. <u> </u>	5. <u> </u>	6. <u> </u>	7. <u> </u>
3. Approximate Elevation if different than above (ft)	3. <u>2208</u>	4. <u>144.0</u>	5. <u>133.0</u>	6. <u> </u>	7. <u> </u>	8. <u> </u>
Procedure for Determining Dry and Wet Density						
4. Standard Count for Density	4. <u>2208</u>	5. <u>144.0</u>	6. <u>133.0</u>	7. <u> </u>	8. <u> </u>	9. <u> </u>
5. Wet Density of soil from gauge (lb/ft ³)	5. <u>139.9</u>	6. <u>130.1</u>	7. <u>3599</u>	8. <u>7.5</u>	9. <u>7.5</u>	10. <u>13.95</u>
6. Dry Density of soil from gauge (lb/ft ³)	6. <u>130.1</u>	7. <u>3599</u>	8. <u>7.5</u>	9. <u>7.5</u>	10. <u>9.24</u>	11. <u>4.71</u>
Procedure for Determining Moisture Content						
7. Standard Count for moisture	7. <u>3599</u>	8. <u>7.5</u>	9. <u>7.5</u>	10. <u>13.95</u>	11. <u>9.24</u>	12. <u>4.77</u>
8. Moisture content of soil from gauge * (%)	8. <u>7.5</u>	9. <u>7.5</u>	10. <u>13.95</u>	11. <u>9.24</u>	12. <u>4.77</u>	13. <u>143.1</u>
9. Check for moisture content [(#5 ÷ #6 x 100)-100] (%)	9. <u>7.5</u>	10. <u>13.95</u>	11. <u>9.24</u>	12. <u>4.77</u>	13. <u>143.1</u>	14. <u>8.5</u>
Take sample (about 10 lb) of material from area tested for density.						
Procedure when sample contains less than 1/10 total weight in stone retained on 3/4" or No. 4 sieve**						
10. Weight of 1/30 ft ³ compacted wet soil + weight of container (lb)	10. <u>13.95</u>	11. <u>9.24</u>	12. <u>4.77</u>	13. <u>143.1</u>	14. <u>8.5</u>	15. <u>134.1</u>
11. Weight of 1/30 ft ³ container (lb)	11. <u>9.24</u>	12. <u>4.77</u>	13. <u>143.1</u>	14. <u>8.5</u>	15. <u>134.1</u>	16. <u>1.0</u>
12. Weight of 1/30 ft ³ compacted wet soil (#10 - #11) (lb)	12. <u>4.77</u>	13. <u>143.1</u>	14. <u>8.5</u>	15. <u>134.1</u>	16. <u>1.0</u>	17. <u>97.0</u>
13. Density of compacted wet soil (30 x #12) (lb/ft ³)	13. <u>143.1</u>	14. <u>8.5</u>	15. <u>134.1</u>	16. <u>1.0</u>	17. <u>97.0</u>	17a. <u>10.5</u>
14. Optimum moisture from dry density curve (Curve No. <u>D</u>) (%)	14. <u>8.5</u>	15. <u>134.1</u>	16. <u>1.0</u>	17. <u>97.0</u>	17a. <u>10.5</u>	18. <u>NO</u>
15. Maximum Dry Density (Curve No. <u>D</u>) (lb/ft ³)	15. <u>134.1</u>	16. <u>1.0</u>	17. <u>97.0</u>	17a. <u>10.5</u>	18. <u>NO</u>	19. <u>A</u>
16. Amount above or below optimum moisture (#14 - #8) (%)	16. <u>1.0</u>	17. <u>97.0</u>	17a. <u>10.5</u>	18. <u>NO</u>	19. <u>A</u>	20. <u>8/22/92</u>
17. Compaction [(#6 ÷ #15) x 100] (%)	17. <u>97.0</u>	17a. <u>10.5</u>	18. <u>NO</u>	19. <u>A</u>	20. <u>8/22/92</u>	
17a. Moisture from zero air voids curve using Line 6	17a. <u>10.5</u>	18. <u>NO</u>	19. <u>A</u>	20. <u>8/22/92</u>		
18. Does material tested meet Specification requirements? Yes <input type="checkbox"/> No <input type="checkbox"/>	18. <u>NO</u>	19. <u>A</u>	20. <u>8/22/92</u>			
19. "A" Rolling ordered; "B" Aerating ordered; "C" Watering ordered	19. <u>A</u>	20. <u>8/22/92</u>				
20. Date Tested	20. <u>8/22/92</u>					

* In percent of Dry Density.
 ** Refer to C-88, lines 28 through 38 when soil sample contains more than 1/10 total weight in stone retained on 3/4" or No. 4 sieve; Use No. 4 sieve for penetration method only.

Computed By CHARLIE COMPACTION Checked By FRED DIRECTOR
 DOT-1635

Figure 6-6. Example of C-135B Nuclear Gauge Compaction Form

Notes